



# Electro Optical Components, Inc.

5464 Skylane Boulevard, Suite D, Santa Rosa, CA 95403

Toll Free: 855-EOC-6300

[www.eoc-inc.com](http://www.eoc-inc.com) | [info@eoc-inc.com](mailto:info@eoc-inc.com)



## Mid-Infrared (MIR) Photodiode Series with a glass cover Lms36PD-03-CG series

3.0 - 3.7  $\mu\text{m}$



Device parameters	Symbol	Value	Units
Sensitive area diameter	d	0,3	mm
Storage temperature	T <sub>stg</sub>	0..+50	°C
Operating temperature	T <sub>opr</sub>	0..+50	°C
Lead soldering temperature (time < 3 seconds, 3 mm from case)	T <sub>sol</sub>	+180	°C
Reverse voltage	V <sub>r</sub>	0.1	V

Photodiode parameters	Conditions	Symbol	Value	Units
Cut-off wavelength	T = 25 °C	$\lambda_{\text{cut}}$	3.55 - 3.7	$\mu\text{m}$
Max. sensitivity range (>80%)	T = 25 °C	$\lambda_p$	3.2 - 3.4	$\mu\text{m}$
Dark current	T = 25 °C; V <sub>reverse</sub> = 0.1 V	I <sub>d</sub>	200 - 600	$\mu\text{A}$
Shunt resistance	T = 25 °C; V <sub>reverse</sub> = 10 mV	R <sub>sh</sub>	0,2 - 0,8	k $\Omega$
Capacitance	T = 25 °C; $\lambda = \lambda_p$	C	150 - 350	pF

All specifications are for photodiode operation at 25°C unless otherwise stated

Photodiodes Lms36PD-03-CG series are fabricated from narrow band-gap InAsSbP/InAs-based heterostructures lattice matched to InAs substrate.

**Photodiode with a glass cover provides a signal that is minimum 3 times higher** than the signal from the same photodiode without a glass cover due to:

- increase of the photodiode effective sensitive area with a glass cover
- increase of the emission got inside the PD crystal

### Typical spectral response

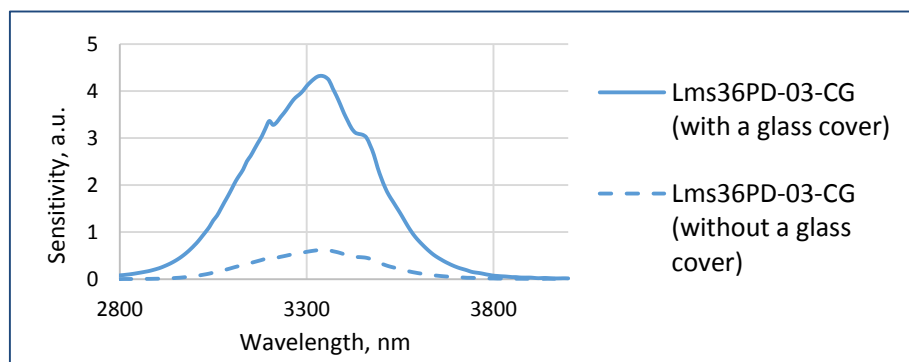

### Typical current-voltage characteristic

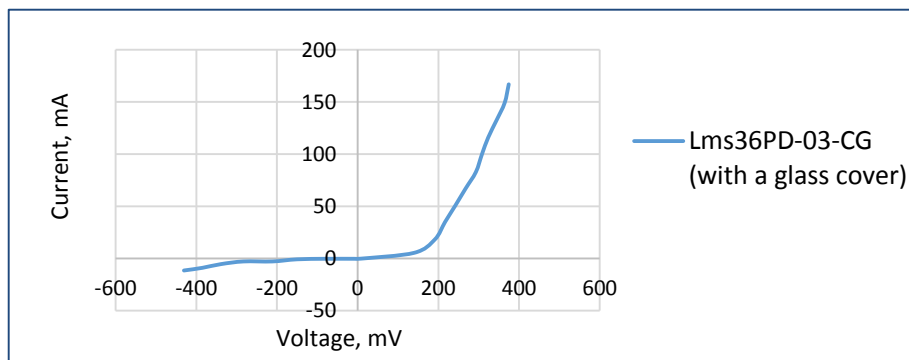

Packages	Model
TO-18 with a glass covering	Lms MIR PD-03-CG
PD with a built-in preamplifier; TO-18 with a glass covering and a parabolic reflector without a window in an aluminium tube	Lms MIR PD-03-CG-R-PA

Recommended modes of PD operation

PD used as a current source (photovoltaic mode)

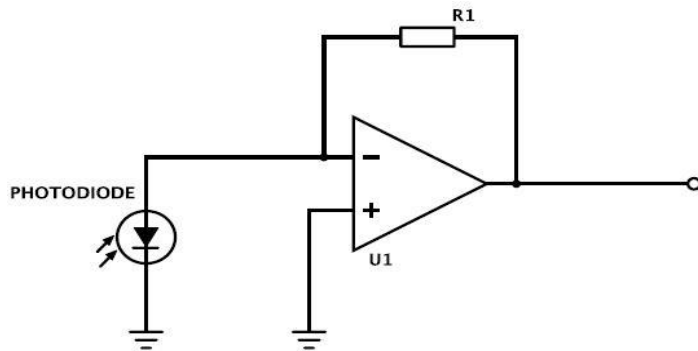

PD used in a photoconductive mode (under reverse bias)

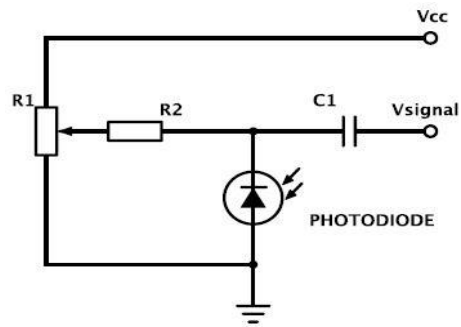

We recommend using **photovoltaic mode**, when PD is used under no reverse bias.  
Use photoconductive mode (mode with reverse bias) with caution.

**IMPORTANT CAUTIONS:**

- check your connection circuit before turning on the PD;
- mind the PD polarity: PD anode is marked with a RED dot;
- do not connect the PD to the multimeter;
- do not touch the glass covering and do not apply any force to it;
- observe the allowable operating temperature range, exceeding this range may cause irreparable damage of the glass cover

Related products:

- **LEDs** - sources of mid-infrared radiation;
- **SDM** - synchronous detector for PD models with preamplifiers - Lms MIR PD-XX-CG-R-PA. SDM synchronous detector measures the voltage signal from the output of photodiode preamplifier and converts it to the DC voltage signal proportional to amplitude of voltage from input.

Technical Drawing

Lms MIR PD-03-CG

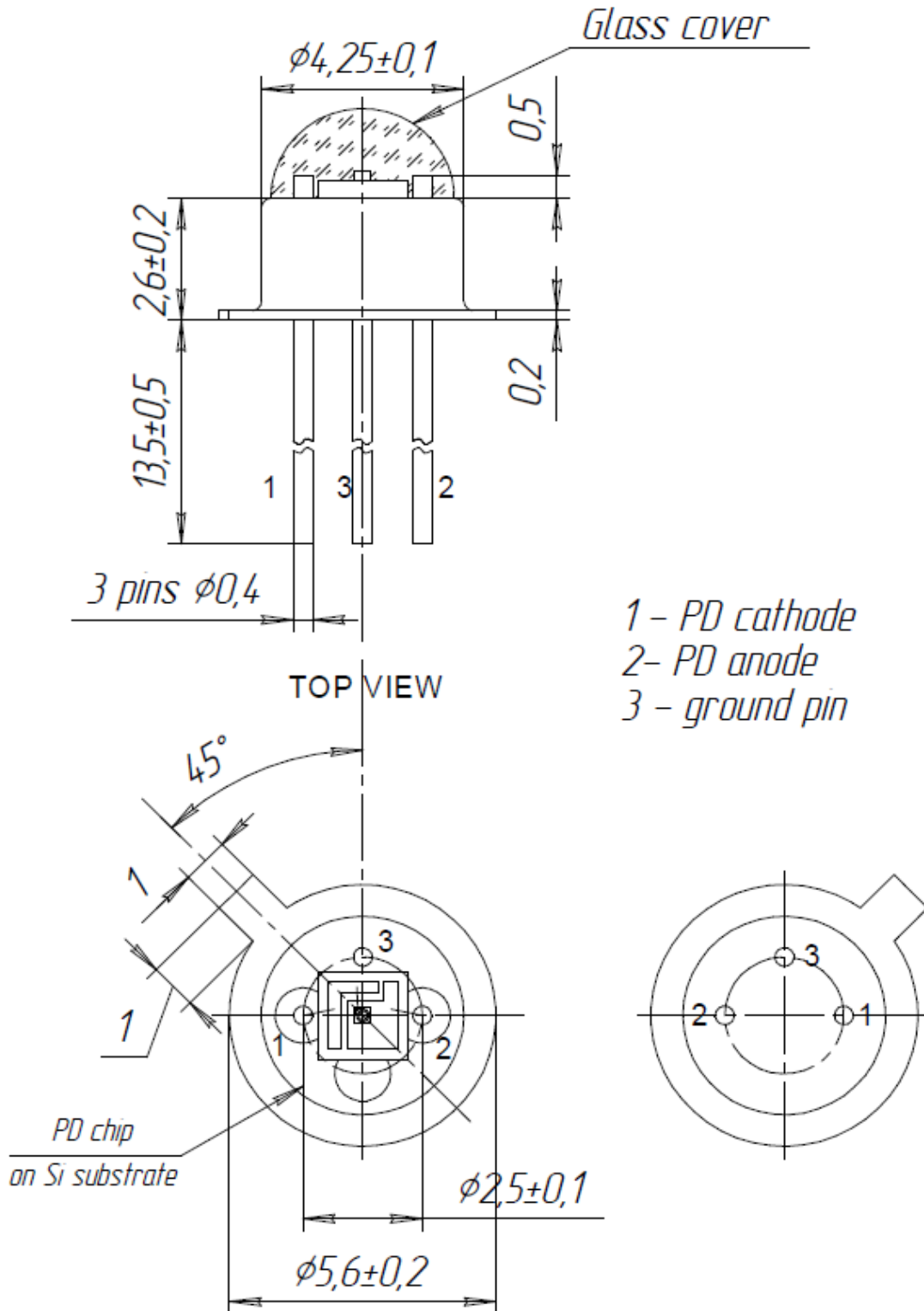

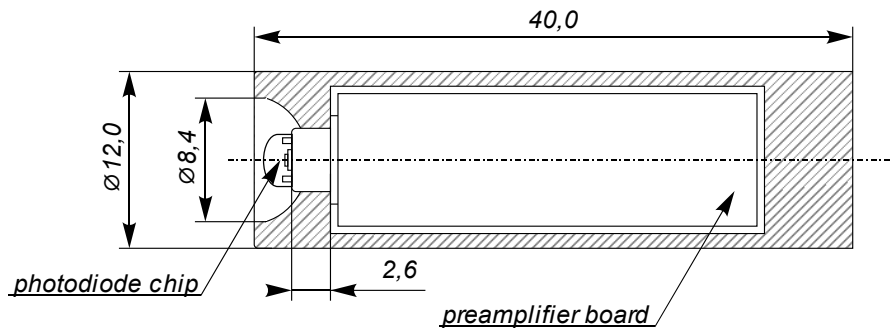

**Connections:**

The output of PD with a built-in preamplifier has four wires:

- "+" power input (to the "+" of the power output terminal block of the SDM synchronous detector);
- "-" power input (to the "-" of the power output terminal block of the SDM synchronous detector);
- output photodiode signal (to the "-" of the signal input terminal block of the SDM synchronous detector);
- output photodiode signal (to the "+" of the signal input terminal block of the SDM synchronous detector).

For the proper connection mind colours of the wires pointed in the technical data provided with the photodiode.