



Three-Electrode Electrochemical Sensors

ABOUT SEMEATECH

SemeaTech is a worldwide leader in sensing technologies focusing on hazardous material detection in work safety, occupational health and environmental protection to monitor toxic gases, such as CO, H2S, Cl2, NH3, SO2, NO2, H2 and O3. Its product lines include the popular 4-series and 7-series industrial grade electrochemical (EC) sensors using standard three electrodes that are completely interchangeable in terms of form, fit and function with the ones made by the other manufacturers in the marketplace. SemeaTech delivers sensors with guaranteed quality in detecting ranges, stability, linearity, repeatability, resolution as well as minimized cross-sensitivity.



FUNCTION PRINCIPLE

The three electrodes on an EC sensor are defined as R (Reference Electrode), S (Sensing Electrode) and C (Counter Electrode) as shown below.

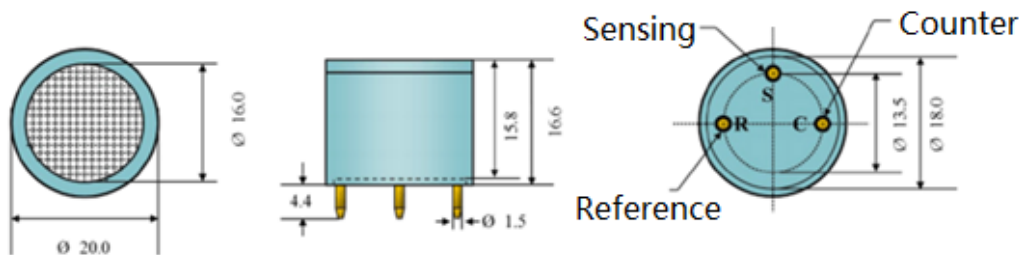

The EC sensor functions by reacting to the target gas and then producing an electrical output signal that is proportional to the gas concentration. The target gas in contact with the sensor first passes through a capillary-type opening and then diffuses through a hydrophobic barrier. It eventually reaches Sensing Electrode surface. The molecules on the electrode are immediately oxidized or reduced to consequently produce or consume electrons to generate an electric current. This is a catalyzed process based on the electrode materials specifically developed for the target gas. For example, carbon monoxide is oxidized at Sensing Electrode per following chemical equation:



Counter Electrode works to balance out the reaction on Sensing Electrode. When oxidation occurs on Sensing Electrode, oxygen is then reduced to form water on Counter Electrode. If it is reduction reactions on Sensing Electrode, Counter Electrode then has reversible reactions accordingly. In this example water gets oxidized per chemical equation as shown below:

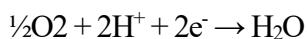

And the overall reaction in this case is:

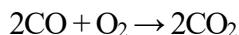

RECOMMENDED CIRCUITRY

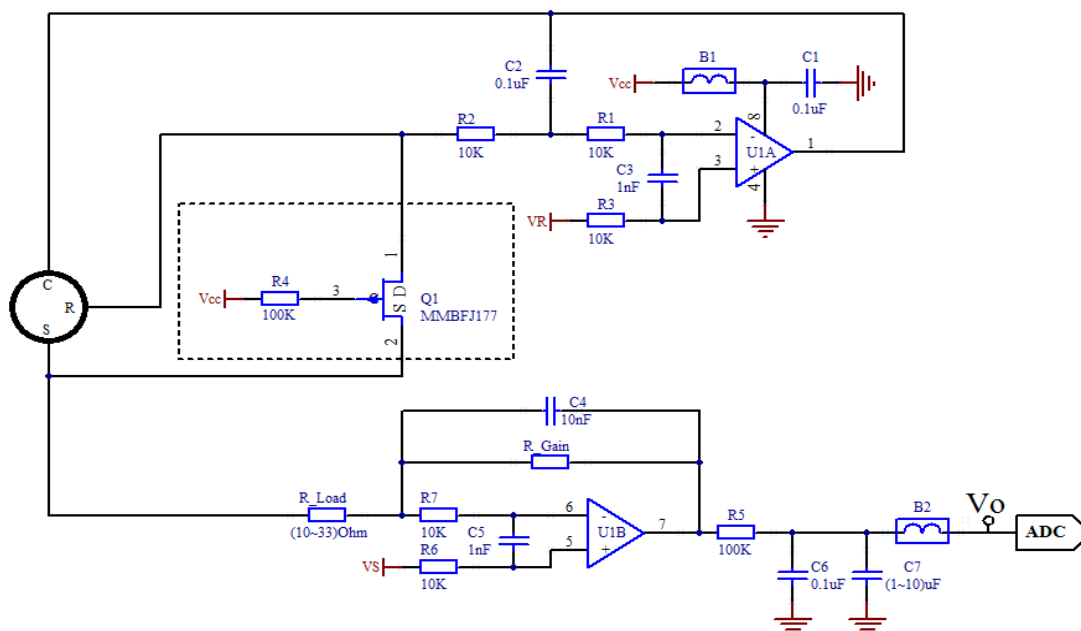

The diagram above is a recommended circuitry for three-electrode EC sensors. It consists of three parts: Potentiostatic Circuit, I/V (current/voltage) Converting Module and Short- Connected Configuration.

1. Potentiostatic Circuit

The potential difference between Sensing Electrode and Counter Electrode should not be smaller than a specific value (depending on the type of sensor) to keep the sensor working normally. Reference Electrode is positioned between Sensing Electrode and Counter Electrode physically in the sensor mechanical structure. Correspondingly Reference Electrode potential should be between the potential of Sensing Electrode and Counter Electrode in the current path. Under the combined effect of the potentiostatic circuit of Reference Electrode and output circuit of Sensing Electrode, the potential difference between Sensing Electrode and Reference Electrode is equal to the minimum value that keeps the sensor working normally. As a result, the potential difference between Sensing Electrode and Counter Electrode is not smaller than that minimum value in order to meet requirements for the sensor to work normally.

The potentiostatic circuit is made up of U1A, R1, R2, R3, C1, C2, C3 and B1 (Ferrite bead). R1, R2 and C3 together form the low-pass filter to reduce high frequency noise between Reference Electrode and Counter Electrode; R2 and R3 are impedance matching resistors. Assuming U1A and U1B are ideal

operational amplifiers, VR is the potential of Reference Electrode, and VS is the potential of Sensing Electrode. Consequently (VS-VR) is the minimum potential difference between Sensing Electrode and Counter Electrode to keep the sensor working normally.

2. Measurement of Sensor Current

The output signal of three-electrode gas sensor is an electric current flowing through Sensing Electrode and Counter Electrode. The best way to measure this current is to use I/V (Current/Voltage) converting module that is made up of U1B, R5, R6, C4, C5, C6, C7, B2, R_Load and R_Gain. In most cases (oxidation), the output current flows out from U1B and then flows into Sensing Electrode through R_Gain and R_Load. The current is proportional to the concentration of target gas. Vo is the output signal that can be calculated using the following equation:

$$V_o = ((I + I_{base}) \times R_{gain}) + V_S \quad (I = \text{sensitivity} \times \text{concentration})$$

Here,

- i) I_{base} is the output current while the concentration of target gas is zero (I_{base} value can be found in the sensor datasheet), and
- ii) C4, C5, C6, C7, R5 and B2 are used for the suppression of signal noise. R6 and R7 act as impedance matching the operational amplifier input.

3. Short-Connected Configuration

For unbiased sensors, Sensing Electrode and Reference Electrode should be short-connected when the circuit power is switched off. This ensures that Sensing Electrode is maintained at the same potential as Reference Electrode, ensuring that the sensor is ready immediately when powered on. The short-connected configuration consists of Q1 and R4. Reference Electrode and Sensing Electrode are connected with a P-channel transistor Q1 shorting the two electrodes at power-off state and opening them during the power-on state.

Sensors that need a bias voltage don't need such a short-connected configuration. In opposite, it is recommended to hold the voltage (mostly 300 mV) all the time between Sensing Electrode and Reference Electrode. This can be realized by connecting the sensor to a battery during power-off.

CONFIGURATION OF BIAS VOLTAGE

1. Biased

The bias voltage of corresponding sensors is shown in the table below.

Sensor Type	V_{bias}
ETO	+300mV(\pm 10mV)
NO	+300mV(\pm 10mV)
C2H3CL	+300mV(\pm 10mV)
HCL	+200mV(\pm 10mV)
Oxygen	-600mV(\pm 10mV)

Notes:

- i) When using biased sensors, the short-connected configuration is not needed. Therefore, Q1 and R4 should be removed in the circuitry;
- ii) $V_{bias} = VS - VR$ (VR and VS is provided by voltage reference IC).

2. Unbiased

For unbiased sensors, Q1 and R4 are required in the circuitry.

KEY POINTS FOR CIRCUIT DESIGN

1. Sensor Polarity

For reductive gas sensors, such as CO, H₂S, SO₂, PH₃ and H₂, the sensor output current flows out from Counter Electrode functioning like “+” pin. After going through the external circuit it flows back to Sensing Electrode which functions like “-” pin. For oxidative gas sensors, such as O₂, NO₂, CL₂, CLO₂ and HF, the sensor output current flows through the entire circuit the other way around.

2. OPA(U1)

The OPA should have very low input bias current on the inverting pin (U1B-6) and low input voltage noise, such as OP07, OPA2378, MCP6V02.

3. Voltage Reference IC

The IC provides the fixed voltage for VS and VR. It requires high precision and low temperature drift coefficient, such as LM285, REF3325, REF1112.

4. R_Gain

The sensor output current flows through R_Gain and then converts to voltage output signal. So it is very important to select R-Gain with high precision and low temperature drift coefficient. The resistor value is determined based on the sensor sensitivity and maximum measuring range (maximum load).

5. **R_Load**

R_load should be selected with the value between 10 ohm and 33 ohm. The higher resistor value is selected, the better performance will be in noise reduction. However higher resistor value meanwhile results the sensor in long response time to the target gas.

6. **RC Filter**

Connecting to U1-B output pin-7, a RC filter consisting of R5, C6 and C7 is recommended to add into the circuitry. To stabilize the voltage output, the RC parameters need to be adjusted.

7. **Filter Capacitor**

C3, C4 and C5 are used as filter capacitors for better EMC performance.

8. **VS Configuration**

For reductive gas sensors, such as CO, H₂S, SO₂, PH₃ and H₂, VS should be set about 0.5V above earth potential (0V) of the circuitry. V_O increases while gas concentration increases. For oxidative gas sensors, such as O₂, NO₂, CL₂, CLO₂ and HF, VS should be set about 0.5V below V_{cc} of OPA. V_O decreases while gas concentration increases.