

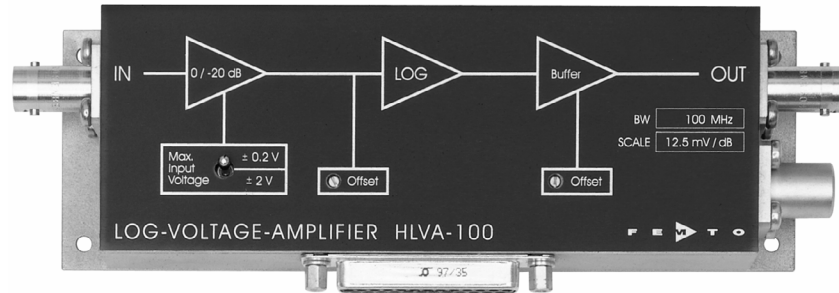

Datasheet

HLVA-100

Logarithmic Voltage Amplifier



Features

- **Wide Dynamic Range** typ. 60 dB, max. 80 dB,
- **5 ns Rise/Fall Time @ 40 dB step**
- **Accuracy ± 1 dB @ pulse width of min. 20 ns**
- **Switchable Input Range $\pm 20 \mu\text{V} \dots \pm 200 \text{ mV}$ or $\pm 200 \mu\text{V} \dots \pm 2 \text{ V}$**
- **DC coupled input**
- **Local and Remote Control**
- **Integrated Sample & Hold Baseline Correction**

- **LIDAR systems**
- **Signal Compression, Pulse Measurements**
- **Time-Resolved Pulse and Transient Measurements**
- **Mass Spectroscopy**
- **Particle Detection**

Block Diagram

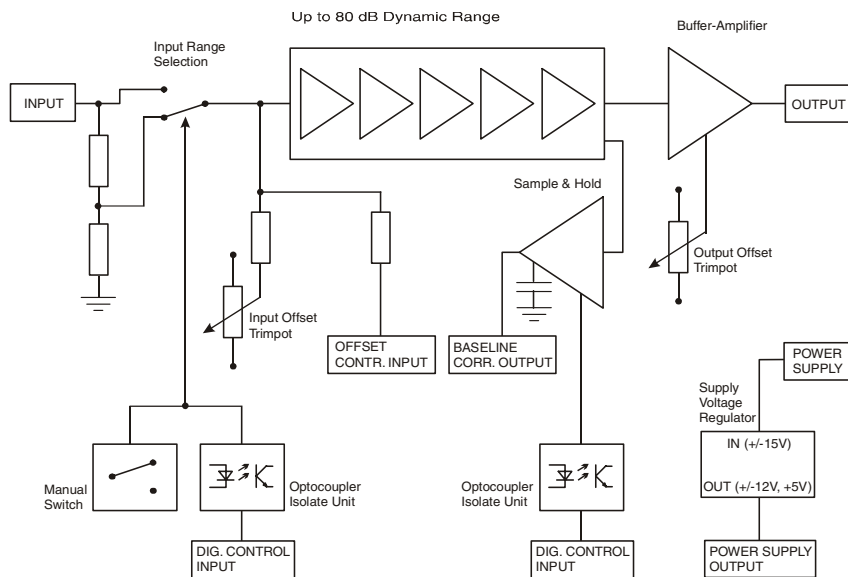

Logarithmic Wideband Voltage Amplifier

Specifications	<i>Test Conditions</i>	<i>V_s = ± 15 V, T_a = 25°C, System Impedance = 50 Ω</i>
Dynamic Performance	Dynamic Range	typ. 60 dB (for accurate amplitude measurements) max. 80 dB (signal detection)
	Input Voltage Range	± 20 μV ... ± 200 mV / ± 200 μV ... ± 2 V switchable
	Scaling	12.5 mV/dB equals 250 mV/ decade (@ 50 Ω Load)
	Linearity	± 1 dB (for pulse of min. 20 ns pulse width)
Pulse Response	Rise/Fall time	5 ns @ 40 dB step
Input	Input Impedance	50 Ω
	Input Voltage Drift	0.6 μV/K
	Equivalent Input Voltage Noise	2 nV/√Hz
	Input BIAS Current	< 4 μA
	Input Offset Voltage	± 2.5 mV, adjustable by Offset-Trimpot and external Control Voltage
Output	Output Impedance	50 Ω
	Output Voltage Range	+50 ... +1075 mV typ. (@ 50 Ω Load) (if Output is adjusted to 1V at 100mV Input)
	Output Offset Voltage Range	± 500 mV, adjustable by Offset-Trimmer
Digital Control	Control Input Voltage Range	Low: - 0.8 ... + 0.8 V High: + 3 ... + 12 V, TTL / CMOS compatible
	Control Input Current	Low: 0 mA High: + 1.5 mA @ + 5 V (Input Range Control) + 7 mA @ + 5 V (Baseline Correction Control)
Baseline Correction	Acquisition Time	30 μs (min. sample pulse width)
	Baseline Hold Droop Rate	1 μV/s (typ. @ 25°C)
	Loop cut-off frequency	1.5 kHz
Ext. Offset Control	Control Voltage Range	± 10 V (for ± 2.5 mV Offset Control)
	Offset Control Input Impedance	100 kΩ
Power Supply	Supply Voltage	± 15 V
	Supply Current	+ 90 / -120 mA typ.
	Stabilized Power Supply Output	± 12 V / max. 100 mA, + 5 V / max. 50 mA
Case	Weight	320 gr. (0.74 lbs)
	Material	AlMg4.5Mn, nickel-plated
Temperature Range	Storage Temperature	- 40 ... + 100 °C
	Operating Temperature	0 ... + 60 °C
Absolute Maximum Ratings	Power Supply Voltage	± 20 V
	Signal Input Voltage	± 3 V @ ± 2 V Input Range Setting - 3 V / + 300 mV @ ± 200 mV Input Range Setting
	Digital Control Input Voltage	+ 16 V / - 5 V

Logarithmic Wideband Voltage Amplifier

Connectors	<p>Input BNC</p> <p>Output BNC</p> <p>Power Supply LEMO Series 1S, 3-pin fixed Socket Pin 1: + 15V Pin 2: - 15V Pin 3: GND</p> <p>Control Port Sub-D 25-pin, female, Qual. Class 2 Pin 1: +12V (Stabilized Power Supply Output) Pin 2: -12V (Stabilized Power Supply Output) Pin 3: AGND (Analog Ground) Pin 4: +5V (Stabilized Power Supply Output) Pin 5 - 6: NC Pin 7: Baseline Correction Output Pin 8: Offset Control Voltage Input Pin 9: DGND (Ground f. Digital Control Pin 10 - 25) Pin 10: Digital Control Input: Input Voltage Range Pin 11: Digital Control Input: Baseline Correction Pin 12 - 25: NC</p>												
Remote Control Operation	<p>Input Range Setting Remote control input is opto-isolated and connected by logical OR to local switch setting. For remote control the switch setting, set the local switch to " ± 2 V " and select the wanted setting via a bit-code at the digital input.</p> <table border="1" data-bbox="861 1097 1085 1232"> <thead> <tr> <th>Input Range</th> <th>Pin 10</th> </tr> </thead> <tbody> <tr> <td>± 2 V</td> <td>Low</td> </tr> <tr> <td>± 200 mV</td> <td>High</td> </tr> </tbody> </table> <p>Baseline Correction The integrated auto-null function can be performed by remote digital control only. The input is opto-isolated by a ultra-fast opto-coupler. Please note the min. pulse width.</p> <table border="1" data-bbox="861 1388 1181 1534"> <thead> <tr> <th>Function</th> <th>Pin 11</th> </tr> </thead> <tbody> <tr> <td>Hold previous value</td> <td>Low</td> </tr> <tr> <td>Null Output</td> <td>High</td> </tr> </tbody> </table>	Input Range	Pin 10	± 2 V	Low	± 200 mV	High	Function	Pin 11	Hold previous value	Low	Null Output	High
Input Range	Pin 10												
± 2 V	Low												
± 200 mV	High												
Function	Pin 11												
Hold previous value	Low												
Null Output	High												

Logarithmic Wideband Voltage Amplifier

Typical Performance Characteristics

Logarithmic Response (@ ± 2 V Input Range Setting)

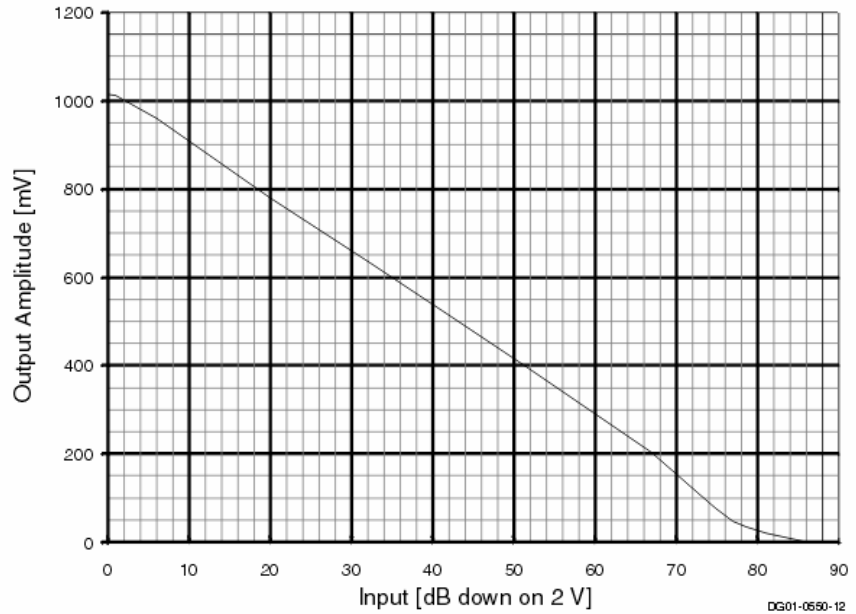

Dimensions

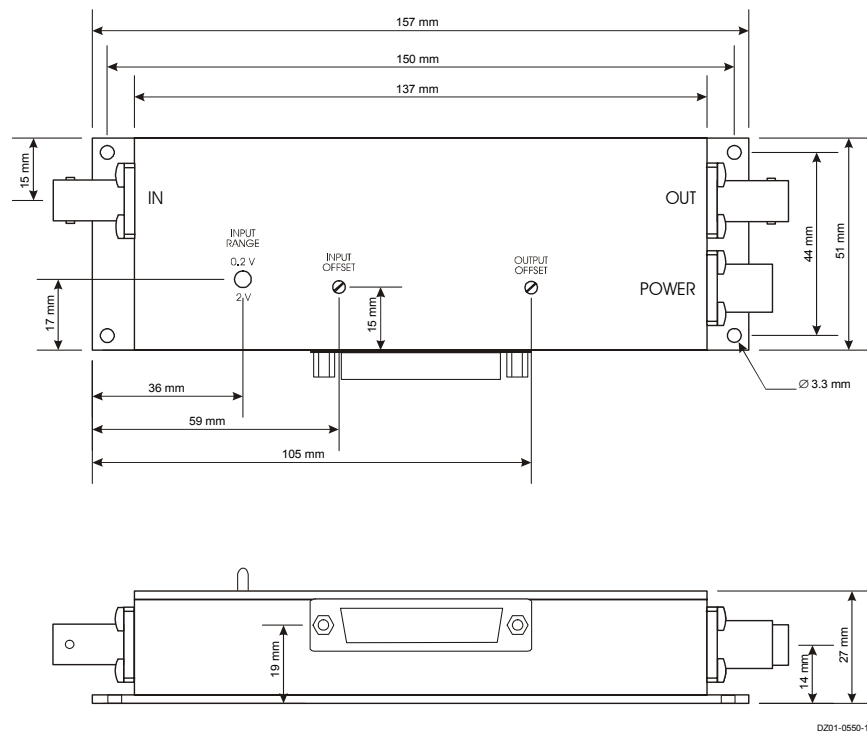

FEMTO Messtechnik GmbH
 Klosterstr. 64
 D-10179 Berlin · Germany
 Tel.: +49-(0)30-280 4711-0
 Fax: +49-(0)30-280 4711-11
 e-mail: info@femto.de
 http://www.femto.de

Specifications are subject to change without notice. Information furnished herein is believed to be accurate and reliable. However, no responsibility is assumed by FEMTO Messtechnik GmbH for its use, nor for any infringement of patents or other rights granted by implication or otherwise under any patent rights of FEMTO Messtechnik GmbH. Product names mentioned may also be trademarks used here for identification purposes only.

© by FEMTO Messtechnik GmbH
 Printed in Germany