



Electro Optical Components, Inc.

5460 Skylane Boulevard, Santa Rosa, CA 95403

Toll Free: 855-EOC-6300

www.eoc-inc.com | info@eoc-inc.com



Small Size Narrow Linewidth Collimated Laser Module



Key Features

- The wavelength stability $<0.01\text{nm}/^{\circ}\text{C}$
- free space
- The power stability is better than $\pm 1\% @ 8\text{h}$

Standard Wavelengths

- 785nm
- 830nm
- 1064nm

Application

- Confocal Microscope
- Fluorescence spectrum
- Laser Particle Analyzer
- Raman spectroscopy
- Up-conversion materials

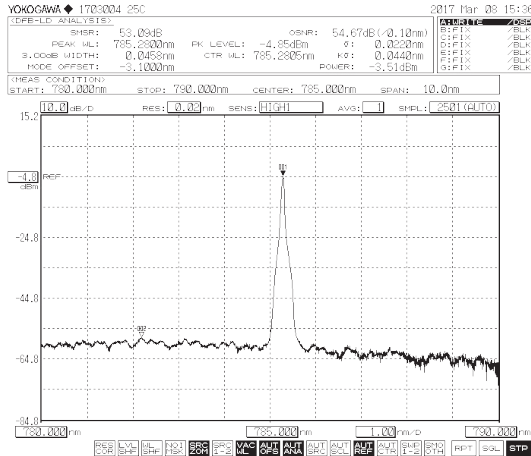

785nm Laser Spectrum

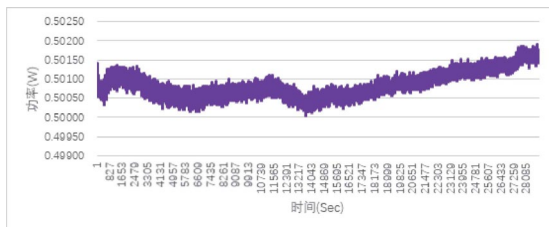

785nm Power Stability@8H

Optical Parameter			
Center Wavelength(nm)	785	830	1064
Output Power(mW)	500	500	500
Wavelength Tolerance(nm)	± 0.5		
Linewidth(nm)	<0.1	<0.1	<0.1
Wavelength Stability	$\pm 0.007 \text{ nm } @ 8\text{H}$		
Power Stability	$\pm 1.0\% @ 8\text{H}$		
SMSR	40dB		
System Parameter			
Adjustibility % full Power	0~100%		
Warm up Time	15 min		
Control Interface	PH2.0-10P		
Connector	free space		
Supply Voltage	4.9V ~ 5.1V @ 2 A		
Power Consumption	$<5\text{W}$ Typ.		
Storage Temperature	0~80% RH		
Storage Humidity	0~55 $^{\circ}\text{C}$		
Operating Temperature	10~35 $^{\circ}\text{C}$ (heat sink is required)		
Weight	$<130 \text{ g}$		
Dimensions	61×43×21.5 mm		

Ordering Information

NLSO Serial Model List			
Center Wavelength(nm)	Output Power(mW)	Part Number	Connector
785	500	NLSO-785-IMW-500	free space
830	500	NLSO-830-IMW-500	free space
1064	500	NLSO-1064-IMW-500	free space

Part Numbering Schema

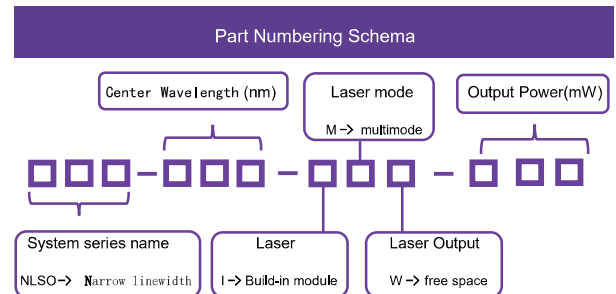

Mechanical Specification

Pin Descriptions		
PIN	Function	Description
1	NC	-
2	GND	Power Supply Ground
3	RT_READ	Rt signal level,output voltage 1.25V, the laser temperature is controlled at 25°C
4	GND	Input Power Ground
5	GND	Input Power Ground
6	+5V	The input voltage is 4.9-5.1V,the maximum current is 2A
7	LASER ENABLE	Set high-level to enable the laser, suspend or set low-level to shut down the laser.
8	Power Control	Voltage input range 0 to 1.2V when control the output power from minimum to maximum
9	+5V	The input voltage is 4.9-5.1V,the maximum current is 2A
10	PD Monitor	PD output

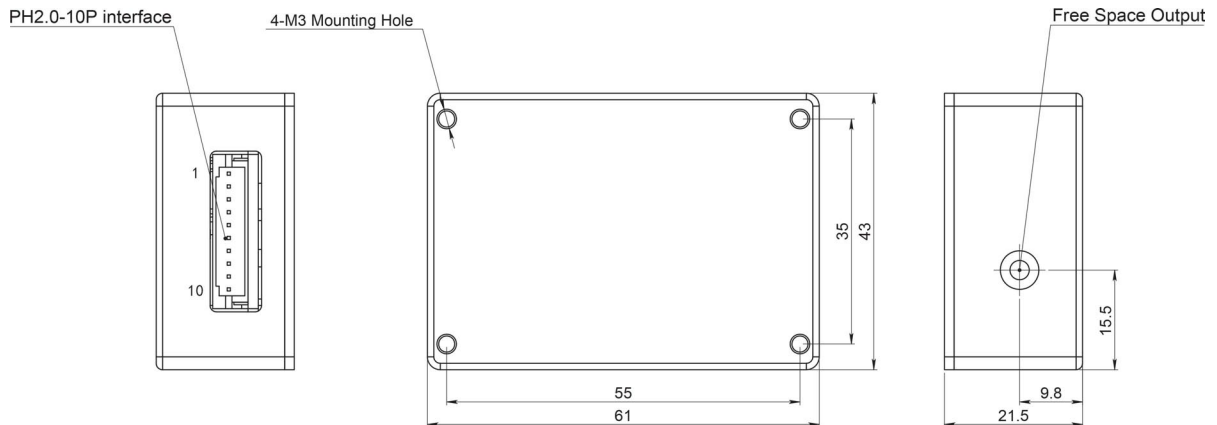

Unit: mm