



Electro Optical Components, Inc.

5464 Skylane Boulevard, Suite D, Santa Rosa, CA 95403

Toll Free: 855-EOC-6300

www.eoc-inc.com | info@eoc-inc.com



MD-1P

PULSE LED MINIDRIVER

INSTRUCTION MANUAL

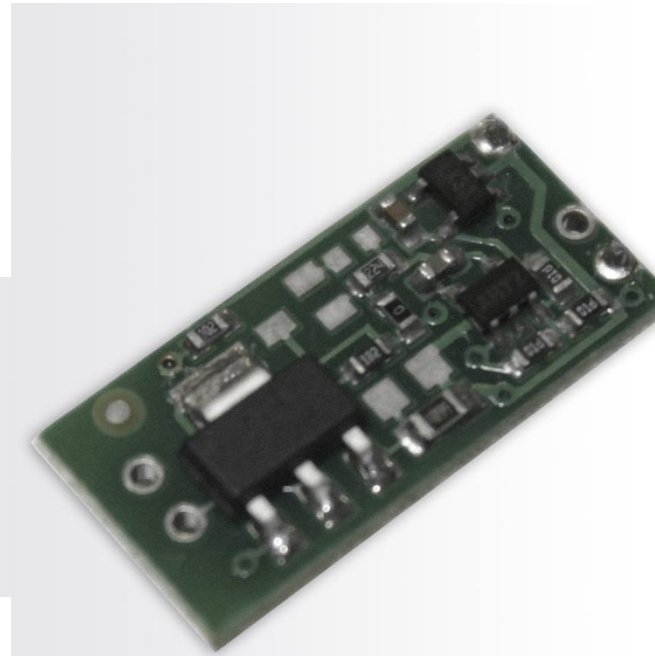

rev. 010115

TABLE OF CONTENTS

General Information	3
Application	3
Features	3
Operation Conditions	3
Operation Mode Description	3
Precautions	3
Driver Layout & Block Diagram	4
Operating Instruction	5
Technical Characteristics	6

GENERAL INFORMATION

Application

mD-1p driver is designed for power supply of standard one-element Mid-IR LEDs.

Features

- **Pulse mode operation** (mode that provides **maximum peak optical power**) with fixed signal data parameters (amplitude, repetition rate and pulse duration).
- Possibility of **synchronisation** with an **external device** (such as **LMSNT SDM synchronous detector**) with the help of **synchronisation output**.

Operation Conditions

Indoor operation only. Ingress Protection Rating IP00.

Operation Mode Description

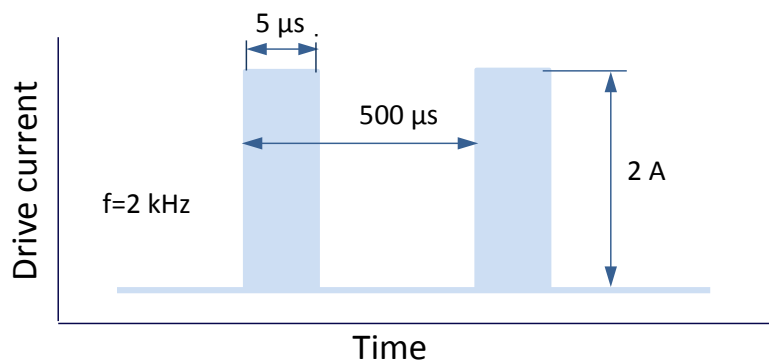

Signal waveform generated by the driver

Precautions

- Turn on the power supply of the LED Driver only after all connections are made and tested.
- Mount or dismount the LED Driver in power-off state only, otherwise it can lead to breakdown.
- Ingress protection rating of the LED Driver is IP00, so please assure the protection of the driver.
- Do not use multimeter to control and adjust current of the LED.

Note! Please refer to your provider if you have any questions.

DRIVER LAYOUT & BLOCK DIAGRAM

Driver Layout

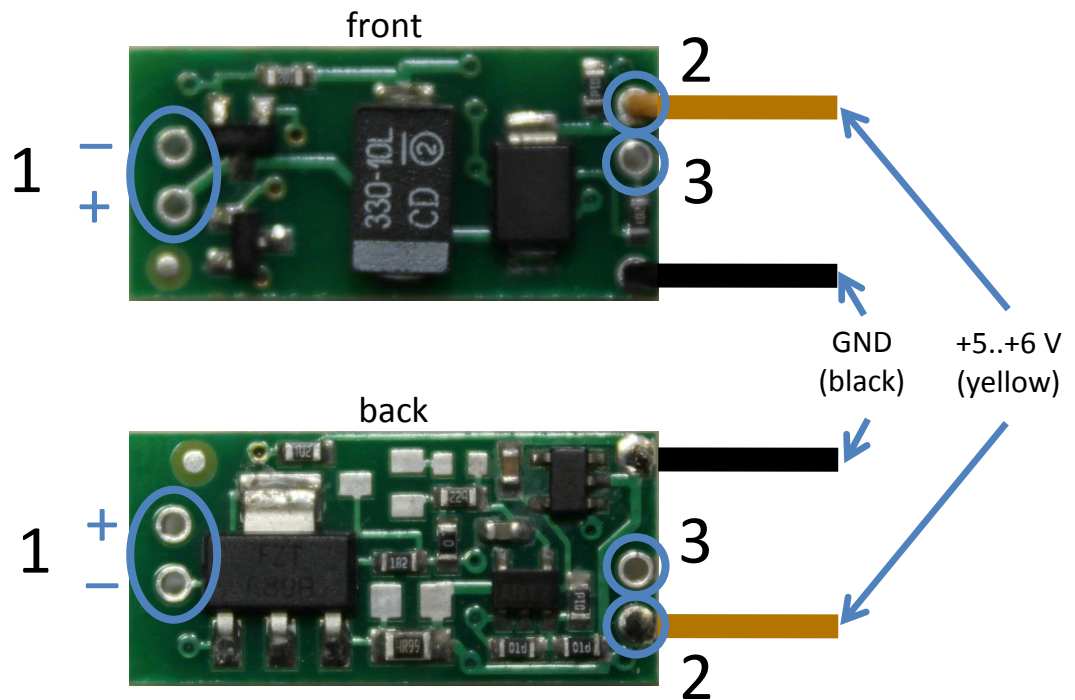

1. LED connection contacts.
2. Power input (+5V) contact*.
3. Synchronization output contact*.

* Power input and synchronisation output contacts have common GND wire (black).

Driver Block Diagram

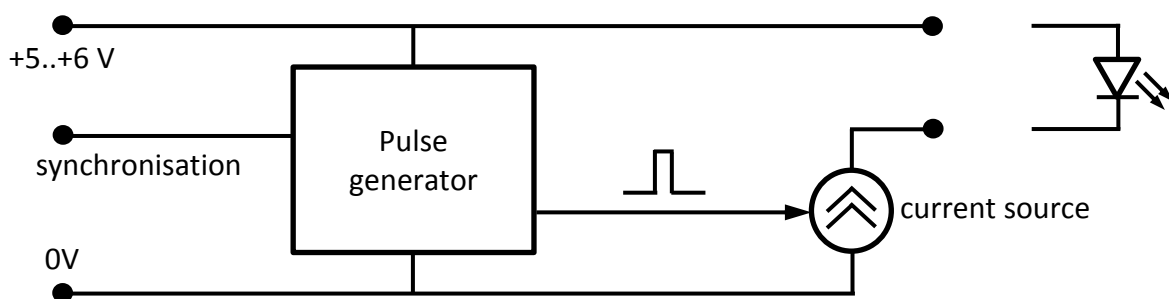

OPERATING INSTRUCTIONS

1. Securely solder the appropriate pins of the LED with LED connection contacts (1).

Note! Contact marked with “LED +” must be connected to the appropriate pin of an LED (marked with a red dot). Improper connection may cause LED damage.

Note! LED case must be electrically isolated from the ground.

2. If you use LMSNT SDM synchronous detector, connect the mD-1p minidriver’s synchronization output contacts (2) with synchronization input terminal block.

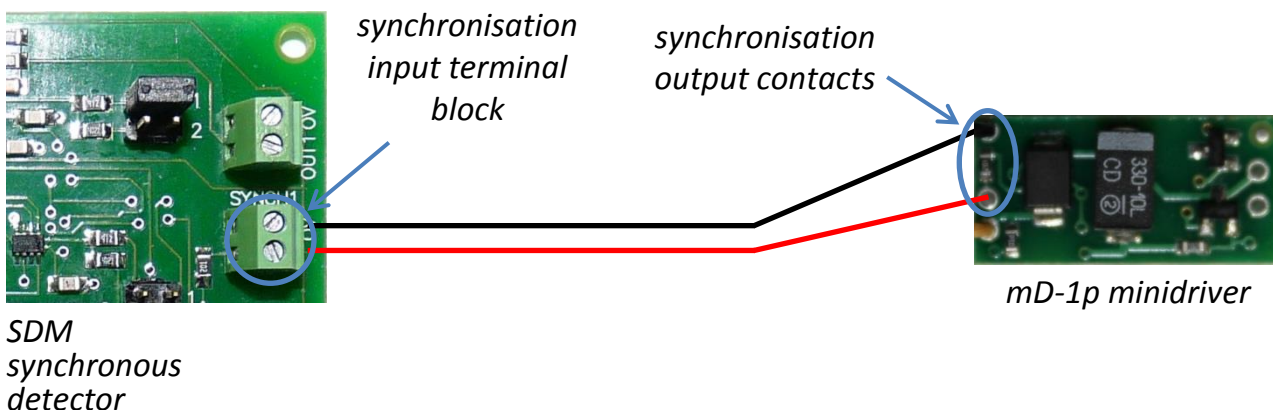

3. If necessary, make all the connections of other boards (synchronous detector, thermocontroller etc.) following the appropriate instructions manuals. Before turning them on check the required connections and modes:

Synchronous detector:

- Photodiode input connection
- Preamplifier power output connection
- Averaging time and signal gain selection
- External signal observing device connection

Thermocontroller:

- Thermistor/D-51 temperature observation block input connection
- Thermocooler output connection
- External connections (if necessary)

4. Connect 5V stabilised power supply to the power input (3).

TECHNICAL CHARACTERISTICS

Main Parameters	
Input voltage	+5..+6 V, stabilized
Voltage tolerance	-5..+5 %
Power consumption	max. 4 W
Board dimensions	24×12 mm
Signal Data	
Pulse duration	5 μ s
Frequency	2 kHz
Output current amplitude	2 A