



Electro Optical Components, Inc.

5464 Skylane Boulevard, Suite D, Santa Rosa, CA 95403

Toll Free: 855-EOC-6300

www.eoc-inc.com | info@eoc-inc.com



[user manual]

Fiber Coupler iD1-FC

Dual-mirror Fiber Coupler
suitable for iS5 FTIR spectrometer



Document Version:	V1.1
Author :	Iskander Usenov
Editor:	Tatiana Sakharova
Date :	2013-05-25
Product	Fiber Coupler iD1-FC
ID:	AP10285
Rev. No.:	V1.1/ 2013-08-19
Type	Fiber Probe Coupler for FTIR-spectrometer iS5 from Thermo Scientific

Table of contents

I	Introduction.....	3
I.1	Safety Instructions	3
I.2	Safety type and class.....	4
I.3	Customer service and warranty	4
I.4	Operating conditions	5
I.5	Storage and Transport	5
I.6	Handling fiber couplers and cables	5
II	Specifications	6
II.1	Mechanical parts.....	6
II.2	Optical parts.....	7
II.2.1	Parabolic mirrors.....	7
III	Content of Delivery.....	8
IV	Installation of the Coupler.....	9
IV.1	Positioning of the coupler.....	9
IV.2	Connecting the reference cable	9
IV.3	Fiber Coupler alignment.....	9
IV.4	Storage configuration.....	10
V	Service and Maintenance	11
V.1	How to store the Fiber Coupler safely.....	11
V.2	Cleaning of mirrors.....	11
V.3	Spare parts	11
VI	Trouble Shooting	12
VII	Attachments	13
VII.1	New safety regulations for servicing laboratory equipment.....	13
VII.2	Confirmation on Decontamination.....	13
VII.3	Test Reports and Material Certificates.....	

3 Specification

I Introduction

The Fiber Coupler iD1-FC is a product of **art photonics** company.

It is intended to attach any fibre cable or fibre probe terminated with SMA905 connectors to the spectrometer Nicolet iS5 from Thermo Scientific.

I.1 Safety Instructions

These units are not designed for use in hazardous areas.

The units supplied should not be repaired by anyone other than **art photonics** engineers or technicians authorized by **art photonics**.

In case of operation trouble, please address to our Customer service department using the form for Confirmation on Decontamination [abbr.: Attachments].

art photonics GmbH, Rudower Schaussee 46, 12489 Berlin, Germany

phone: +49(0)30-677-988-70

fax: +49(0)30-677-988-799

e-mail: info@artphotonics.de

web: www.artphotonics.com



Conditions for operation!

To operate the fiber coupler with a spectrometry system, all specified conditions have to meet the requirements. Otherwise trouble or defects may occur.



Sensitive optical elements!

Please note the advice given below concerning the handling of sensitive optical elements.



Spare parts!

Only use original spare parts. If it is necessary to change parts not listed in the following chapters, please refer to art photonics customer service. Do not repair or change parts which are not explicitly mentioned in this manual.



Components designed to fit together!

Always use the spectrometer units which have been assembled for you at the original installation. Only use original spare parts. If it is necessary to change parts not listed in the following chapters, please refer to art photonics customer service. Do not repair or change parts which are not explicitly mentioned in this manual. Always contact art photonics Customer Services if you are considering an exchange.

Record the operating parameters of your spectrometer setup

The operating parameters of the system should be checked, defined and recorded each time a change is made to the measurement system (e.g. change of parabolic mirrors, precision sliders etc.). This can either be done by carrying out the measurements described in the following chapters or individually defined standard measurements.

1.2 Safety type and class

The modular spectrometer systems or accessories were constructed and tested according our test procedures and left our factory in perfect technical condition according to related safety regulations. If this condition is to be maintained and in order to guarantee safe operation, you must comply with all advice and warning notes in this manual.

1.3 Customer service and warranty

With the exception of o-rings and protective caps changes as well as the maintenance and service tasks mentioned in the following chapters, it is not allowed to service or repair components or accessories. In case of self service the guarantee by art photonics will be no longer valid.

Only the manufacturer and persons authorised by the manufacturer are permitted to carry out repairs.

Please contact Customer Services in case of problems with your system or individual components.

5 Specification

I.4 Operating conditions

Install your device with Fiber Coupler in easily accessible place.

Avoid contact of inside of the coupler with water or chemicals.

Protect optic elements against dirt.

Environmental temperature for the coupler (not for coupled equipment): + 0° C to + 50° C

Working temperature for the coupler (not for coupled equipment): 0° C to + 50° C

Do not use this Fiber Coupler in hazardous areas.

I.5 Storage and Transport

Before starting the accessory the specified temperature range has to be reached. Therefore allow the accessory to acclimatize for at least 0.5 hours to its new environment. Store the coupler in dry places only. No further safety measures are required. Although the components are robust, jolts and rough handling should be avoided.

I.6 Handling fiber couplers and cables



Handle parabolic mirrors with care.

- Do not take the coupler out of iD1 case!
- Do not touch optical surface of parabolic mirrors with fingers/napkin/any tool ! The surface can be easily scratched resulting in reflection (transmission through the coupler) drop.
- Do not rinse fiber coupler. Do not immerse fiber coupler into liquids. The fiber coupler is not sealed in the iD1-accessory thus the penetration of water or chemicals inside the coupler will result in it's damage. Ask the manufacturer for the advice if fiber coupler need cleaning.



Handle fiber cable with care.

- For optical reference cable in use: avoid tension, torsion and bending for radius less than 50mm. Hold the connector not cable protective tube when pulling it out of the adaptor. For handling with other optical cables and probes refer to handling rules for them.
- Store fiber coupler which is not in use in its protective storage cartons.
- Prevent the drop of the coupler.
- Be careful inserting the fiber cable into the coupler.

II Specifications

Fiber Coupler iD1-FC is intended to attach any fibre cable or fibre probe terminated with SMA905 connectors to FTIR spectrometer Nicolet iS5.

II.1 Mechanical parts

Total length:	136 mm
Total height:	74 mm without align handles, 85 mm with alignment handles
Total width:	60 mm
SMA height alignment:	12 mm
Axis-to-axis:	76 mm (between fiber connectors)
Connectors:	SMA905
Case material:	Aluminium alloy
Weight:	0.5 kg

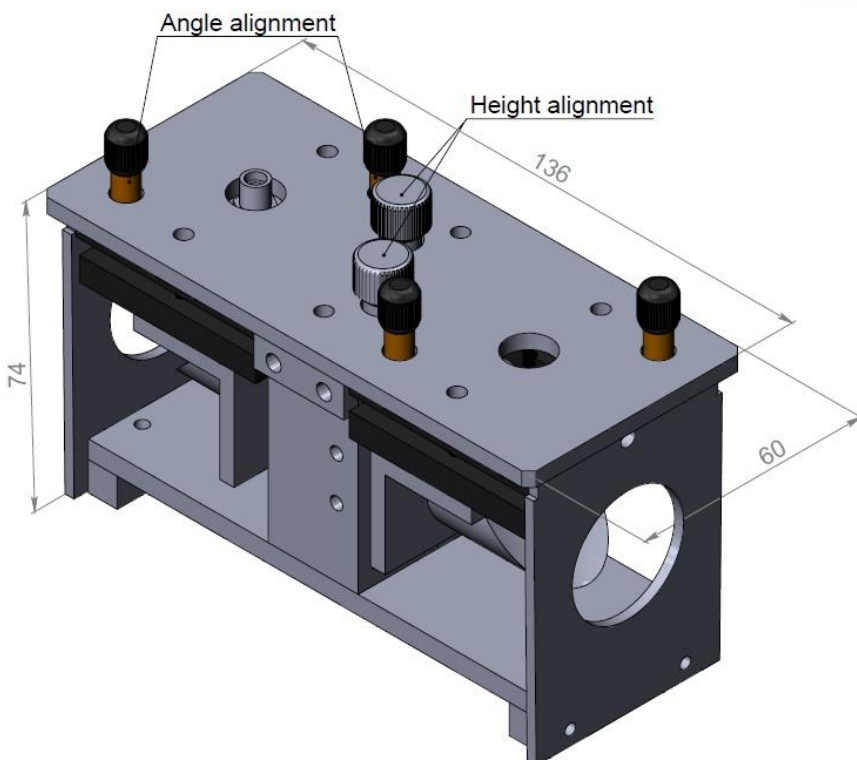

7 Specification

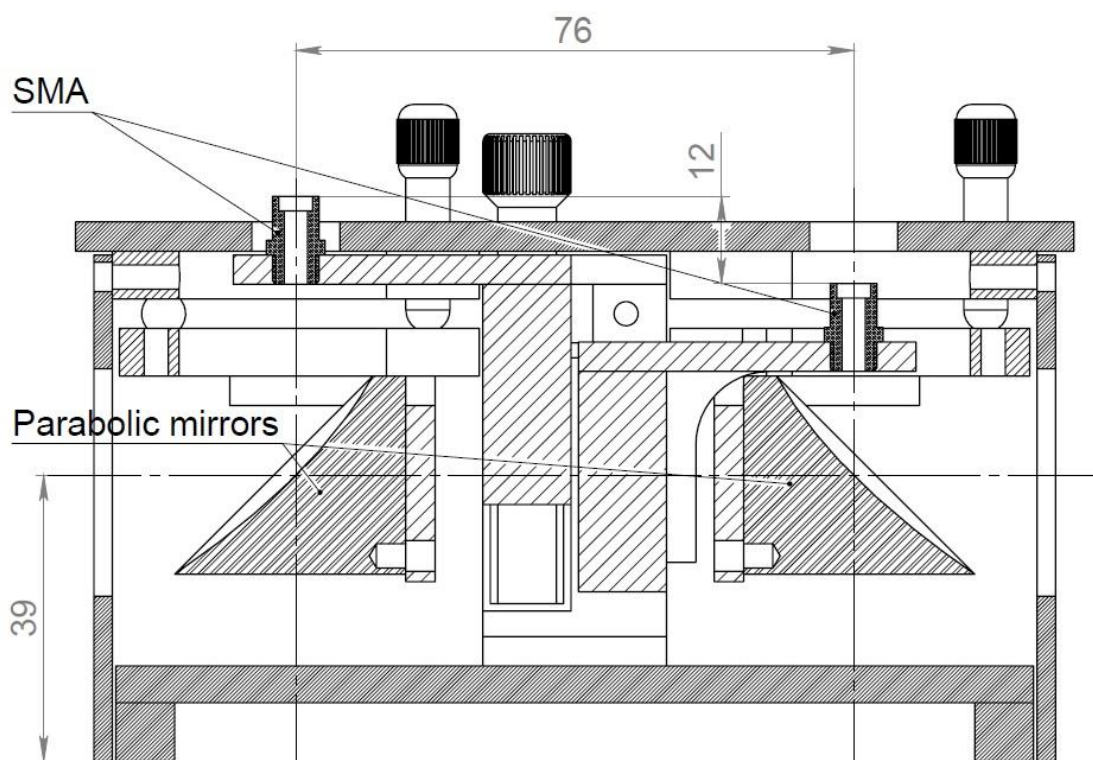

II.2 Optical parts

II.2.1 Parabolic mirrors

Diameter: \varnothing 27 mm

Focus: 15 x 30 mm

III Content of Delivery

The Fiber Coupler iD1-FC package should include the following items:

- 1 x Fiber Coupler (1)
- 1 x iD1-accessory case (2)
- 1 x Reference fiber cable (3)

Fiber Coupler is mounted inside the iD1-accessory case. Do not take the coupler out of the iD1-accessory case!.



9 Installation of the Coupler

IV Installation of the Coupler

The pictures below explain step by step how to insert and adjust the coupler. Some important issues are mentioned as well. The following picture shows which parts are needed to install the fibre coupler.

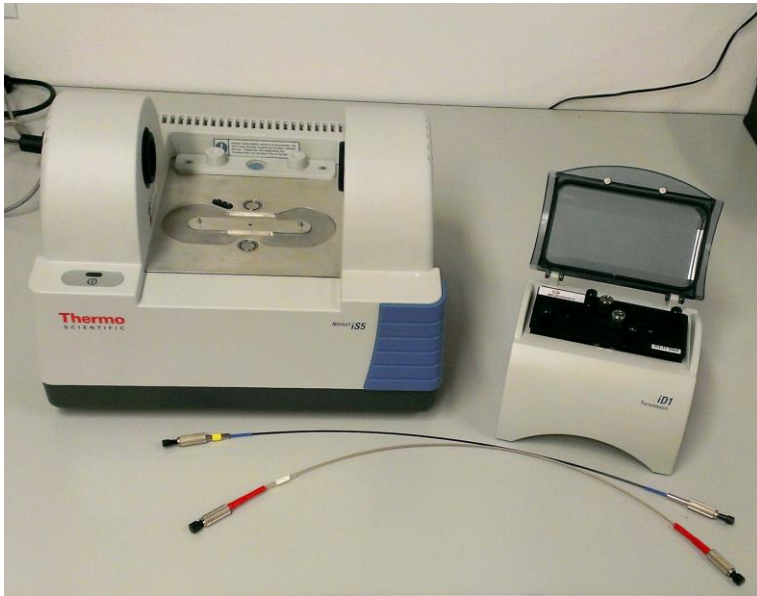

1. Spectrometer iS5.
2. Reference cables
PIR 400/500 and CIR
250/300
3. iD1-accessory with art
photonics coupler iD1-FC
inside.

Do not take the coupler out of the iD1 case!

Don't touch the mirrors by hands. It could result in poor coupling efficiency.

IV.1 Positioning of the coupler

Insert the coupler into sample compartment of the spectrometer. It should not move or rock.

IV.2 Connecting the reference cable

The next step is to insert the reference cable connectors into SMA adaptors of the coupler.

The preparation is ready for the alignment of fibre coupler to get highest signal possible

IV.3 Fiber Coupler alignment

At first switch the spectrometer and computer on. Start 'Omnic' software and switch it on Expt set → Bench → Single Beam. Figure 7 shows the alignment mode (Single Beam).

Installation of the Coupler 10

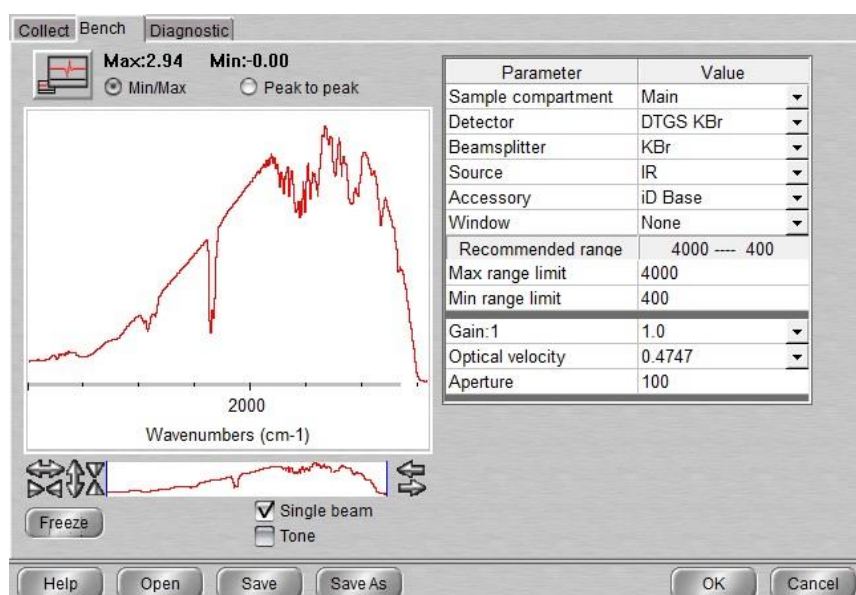

The coupler is delivered with pre-aligned mirrors. Minor additional adjustment is only needed. The alignment should start with changing the z-axis position (vertical position) of SMA adaptors one by one. When the highest signal is reached then adjust output mirror using two black screws on the left side. Afterwards align the screws on the right side to optimise the mirror at the light source.

The whole alignment must be done carefully. Don't align too fast because the response of detector is delayed.

Normally the adjustment can be done once then only slight correction is necessary for any other attachment of fibre cables and probes. However, make the correction of optimal mirrors positions for better signal and reproducible measurement results.

IV.4 Storage configuration

- Close the cover of the iD1-accessory case.
- Put the protective caps onto the windows on both sides of iD1-accessory case.
- Store the reference cable with the Fiber Coupler.

11 Installation of the Coupler

V Service and Maintenance

V.1 How to store the Fiber Coupler safely

If not in use then the Fiber Coupler should be stored in a dry place. Protection against dust is recommended.

Store the reference cable with Fiber Coupler.

V.2 Cleaning of mirrors

Clean the mirrors only with compressed air flow.

V.3 Spare parts

Reference cable

AP 10156 or AP 10158 on request

VI Trouble Shooting

Too low signal

- Check the system using reference cable with known signal
- Check fibre ends quality at both ends of the cable/ probe
- Check surface of the parabolic mirrors
- Check if the connectors are in good condition.

No signal

- Check position of the iD1-accessory in the iS5 spectrometer

13 Attachments

VII Attachments

VII.1 New safety regulations for servicing laboratory equipment

VII.2 Confirmation on Decontamination

Form sheet for return

VII.3 Test Reports and Material Certificates

NEW SAFETY REGULATIONS FOR SERVICING LABORATORY EQUIPMENT

Dear Customer,

For instruments used in analytical laboratories (e.g. bio-, chemical- or pharmaceutical environment) it cannot be ruled out that service personnel could be exposed to health risks by coming into contact with residues of hazardous substances, especially when the instrument or accessories have been used for making measurements using radioactive, infectious or toxic substances.

The current regulations and laws, as well as the extended guidelines and norms, stipulate that we, as a manufacturer of measuring systems, observe more stringent safety regulations in order to ensure the safety of our employees. These regulations and laws include:

- The chemicals ordinance for protection from hazardous substances
- The hazardous substances ordinance, technical rules for hazardous substances
- The radiological protection ordinance
- The accident prevention regulations biotechnology, safety tests concerning biological safety according to UVV, VBG 102
- The guidelines of the professional associations, working in contaminated areas

Moreover, the environmental regulations issued by the environmental protection and industrial inspection board as well as the quality assurance system DIN/ISO 9001, which was awarded to J&M, also have to be observed.

Therefore, prior to allowing any repair work in your laboratory or before returning the instrument to us we would ask you, either to carefully clean, disinfect or decontaminate the instrument or components to be serviced, or confirm that the instrument or components have not come into contact with any hazardous substances.

The enclosed "Confirmation on Decontamination" should be filled out and attached to the Shipping papers together with your repair order, or handed out directly to our service technicians in your laboratory.

We are unable to commence repair work without a declaration that the instrument has been decontaminated. Should the declaration not be received within three weeks we regret that we must for safety reasons return the instrument unrepaired, at your cost.

For further questions, please do not hesitate to contact us directly.

15 Attachments

Confirmation on Decontamination

If you return an instrument or component (e.g. accessory) to AP for servicing purposes which is not properly decontaminated, there will be a health risk for AP employees. We therefore need your confirmation that the instrument or component was decontaminated and cleaned properly before shipping. If the form below is not filled in accordingly and completely, we will reject the instrument. This is needed to protect our employees. We kindly ask you for your understanding.

Instrument / component _____	Serial no. _____
Instrument or component has come into contact with:	
<input type="checkbox"/> radioactive substances Isotope _____ _____	How decontaminated / cleaned: _____ _____
<input type="checkbox"/> chemical reagents R-and S-rules _____ _____	How decontaminated / cleaned: _____ _____
<input type="checkbox"/> biological material specify _____ _____	How decontaminated / cleaned: _____ _____
<input type="checkbox"/> contagious agents specify _____ _____	How decontaminated / cleaned: _____ _____
<input type="checkbox"/> I hereby confirm that the instrument or component specified above was not contaminated with any of the above mentioned substances / reagents / agents	
<input type="checkbox"/> I hereby confirm that the instrument or component specified above was decontaminated / cleansed using the appropriate method.	
Date: _____	signature: _____
(please print)	
name: _____ _____	address: _____ _____
title: _____	phone: _____ fax: _____