

	SiC-photodiodes JEC1,6R / JEC5R
-----------------------------------------------------------------------------------	--------------------------------------------

preliminary data sheet

characteristics :

- ◆ large area monolithic SiC photodiodes
- ◆ active aerea: 1,55 or 5 mm²
- ◆ spectral range: 215 ... 360 nm
- ◆ high UV-responsivity: 0,16 A/W
- ◆ hermetically sealed TO39-package
- ◆ components are ROHS and WEE conform

applications :

- ◆ UV-measurement only
- ◆ UV-source control
- ◆ flame detection

maximum ratings :

- ◆ reverse voltage 20 V
- ◆ operating temperature range - 40 °C ... 100 °C
- ◆ storage temperature range - 40 °C ... 100 °C
- ◆ soldering temperature (3s) 260 °C

technical data :

 test conditions, as not otherwise specified: T_A = 25 °C , V_R = 0 V

parameter	test condition	JEC1,6	JEC5	unit
active area		1,25 x 1,25	Ø 2,525	mm ²
maximum of spectral responsivity	$\lambda_{max} = 270 \text{ nm}$	0,16	0,16	A/W
spectral range	$S = 0,1 \times S_{max}$			
λ_{min}		215	215	nm
λ_{max}		360	360	
absolute spectral responsivity	$\lambda = 254 \text{ nm}$	0,14	0,14	A/W
dark current I _R	E = 0 lx	100	200	fA
rise time t _r of photocurrent	R _L = 50 Ω $\lambda = 254 \text{ nm}$ I _P = 10 µA	tbc	tbc	ns
capacitance	F = 1 MHz E = 0 lx	250	1.000	pF

SiC-photodiodes JEC1,6R / JEC5R

relative spectral responsivity

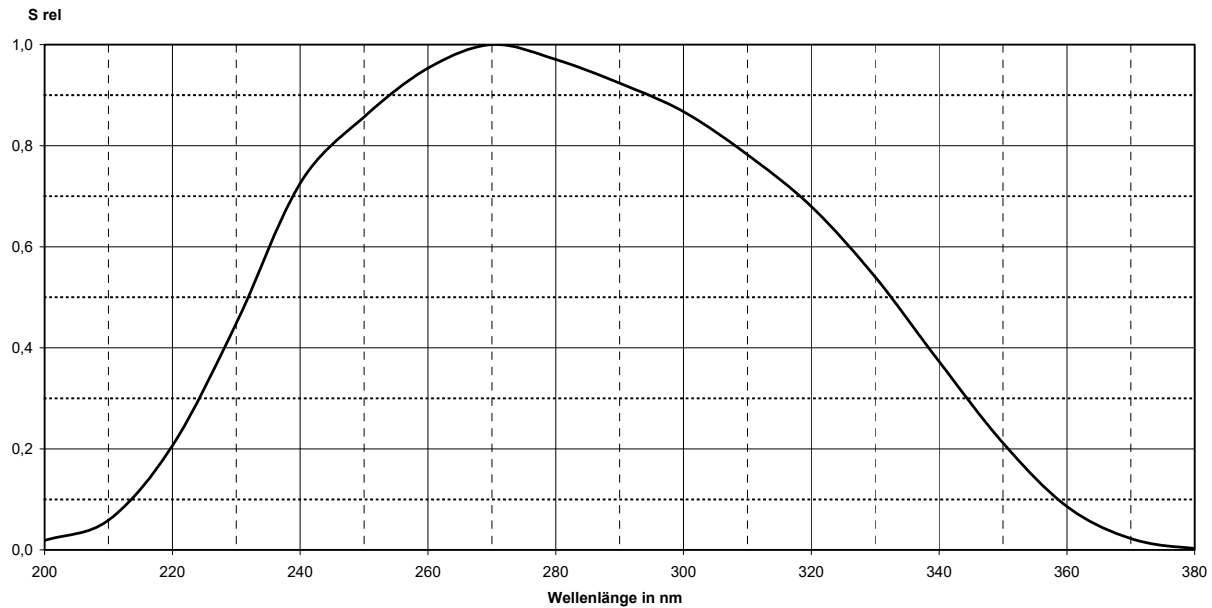

Package dimensions

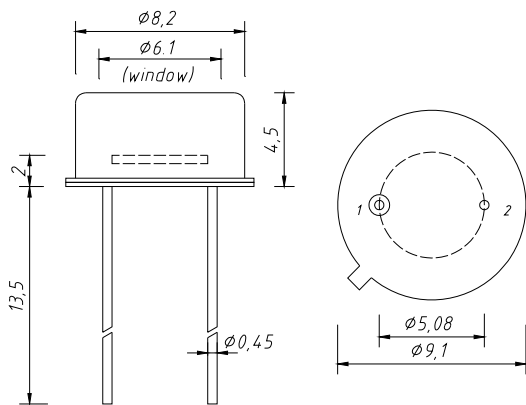

1 anode
2 cathode & case

bottomview

application example

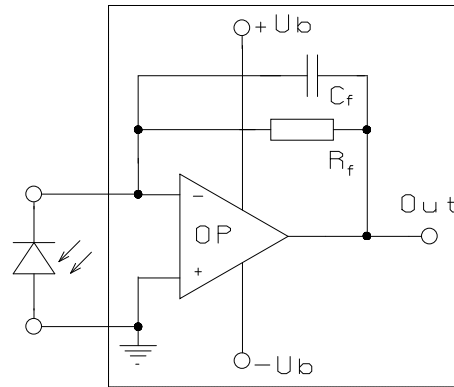

The application example shows a typical circuit. R_f is responsible for the gain of the circuit. C_f compensates the reverse junction capacitance of the photodiode and the input capacitance of the OP-amp. The exact value of C_f depends on R_f , used OP-amp and capacitance of the circuit. A typical value is 1 pF.

The chart shows dependence of amplitude of the application circuit with OP-amp = AD795, $R_f = 10 \text{ M}\Omega$ and $C_f = 1 \text{ pF}$.

