



# Quadrant - Photodiode JQI 5P, JQI 20P and JQI 50P with integrated amplifier

- characteristics :**
- ◆ Si - PIN - Photodiode
  - ◆ spektral range 360 ... 1060 nm
  - ◆ active area 5, 20 u..50 mm<sup>2</sup>
  - ◆ possible solution of position 0,1 μm

- application :**
- ◆ adjustment detector
  - ◆ star leading detector in astronomic equipment

## absolute maximum ratings:

operating voltage	± 18	V
power consumption	300	mW
operating temperature range	- 25 °C ... 70	°C
storage temperature	- 40 °C ... 85	°C
welding temperature (3s)	260	°C

## technical data :

common measuring conditions, as not otherwise specified:  $\gamma_a = 25\text{ °C}$ ,  $V_{cc} = \pm 15\text{ V}$

parameter	test condition	JQI 5P	JQI 20P	JQI 50P	units
active area		4 x 1,25	4 x 5	4 x 12,5	mm <sup>2</sup>
dark offset voltage	E = 0 lx	typ. ±1, max. ±3			mV
saturation voltage		- 13,5			V
noise voltage	B = 15 kHz	typ.1, max.2,5			mV <sub>rms</sub>
absolute spectral responsivity	λ = 850 nm	55			mV/μW
feedback resistor		100			kΩ
operating voltage		min. ±5, typ.±15, max. ±18			V
operating current		± 2,5			mA
rise-/falltime		40	50	65	μs
bandwidth	- 3 dB	30	15	6	kHz

## relative spectral responsivity

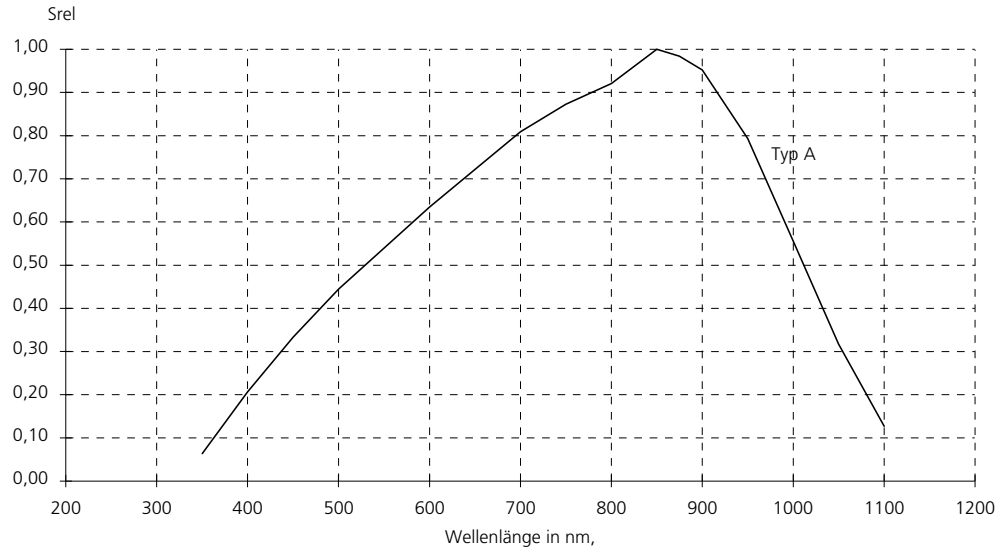

## internal circuit

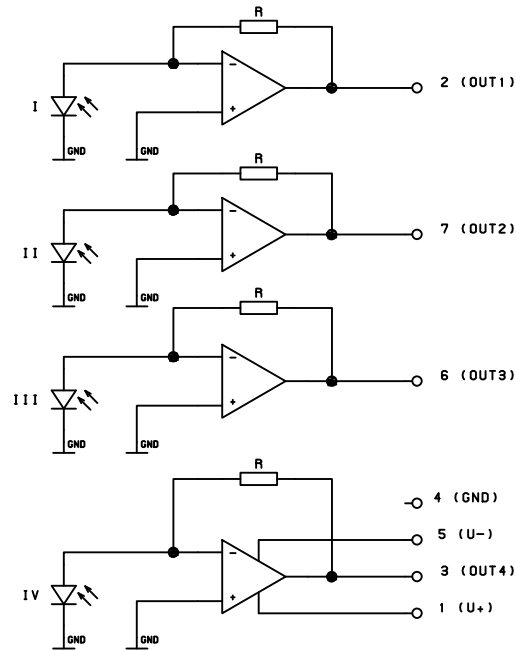

## package

