



Electro Optical Components, Inc.

5464 Skylane Boulevard, Suite D, Santa Rosa, CA 95403

Toll Free: 855-EOC-6300

www.eoc-inc.com | info@eoc-inc.com



P1500 BLACK EDITION GENERAL SPECIFICATIONS

MICROPUMPS BLACK EDITION FROM XAVITECH

Xavitech's BLACK Edition is our pump model version with the most functionality and flexibility. Our goal is for you to be able to use this micro pump in your new or in-place system in an easy and convenient way.

- Options, guaranteed service lifespan
- Maximum value
- Adapted functions

CHOOSE THE SERVICE LIFESPAN FOR YOUR MICRO PUMP

The service lifespan of a pump is an extremely critical point when it comes to choosing a new pump. With the BLACK Edition from Xavitech, you do not need to adapt your decision to the service lifespan that the pump supplier sets. You choose the service lifespan that passes your system.

All systems are different and have different requirements. We believe that you the customer should be able to choose the service lifespan that exactly fits your system and business model, and not pay for a greater service lifespan than you actually need. To solve this problem, we created the BLACK Edition of our pumps.

ADAPT THE BLACK EDITION TO THE SYSTEM'S REQUIREMENTS

BLACK Edition even offers all of the advantages of Xavitech's other pumps. Du can choose to calibrate your micro pump for the flow you need in your system, which allows for less testing in your production. If you like, you can even select the voltage the pump runs on, and if you prefer, cables or flex contacts exiting the pump.

You also have the opportunity to influence how the pump will work in its application. Each micro pump has a built-in mini computer and we create customized software for various purposes. We are very interested to learn how you would like your ideal pump to work. Very likely, we can come extremely close to it with a BLACK Edition pump from Xavitech.

GENERAL FLOW PERFORMANCE P1500 PUMPS

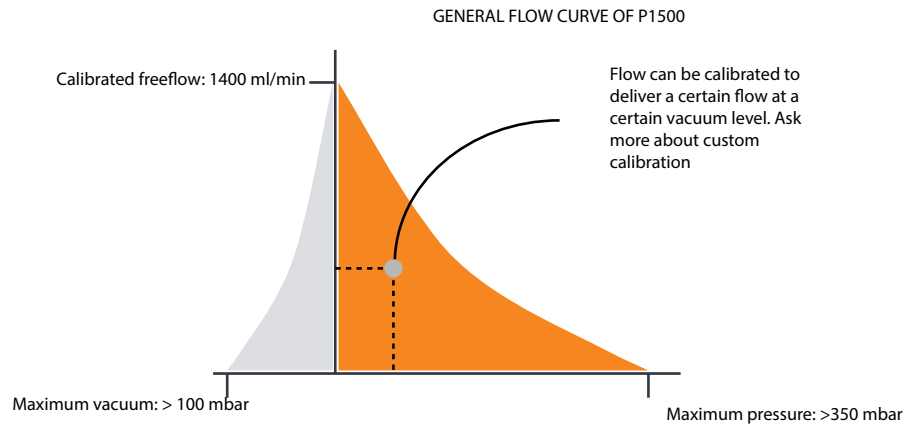

PUMP MODEL	P1500 BLACK EDITION
PERMISSABLE AMBIENT TEMP	0 - 55 C (Extended temp. range can be approved)
PERMISSABLE MEDIUM TEMP	0 - 55 C (Extended temp. range can be approved)
FLOW MEDIA	Air and gas. (Ask for compability)
WETTED PARTS	EPDM and PPS (Other materials on request)
	Other materials can change flow specifications, ask for information
CAPACITORS	Missing VCC capacitor can damage the pump. See electrical interface datasheet
CONNECTIONS	Incorrect lead connection can damage the pump
FILTERS	To insure lifetime, air filters should be used in order to prevent contaminations like dust to enter the pump
FLOW TOLERANCES	Flow can vary -/+ 5% of calibrated specification between individual pumps
VACUUM AND PRESSURE TOLERANCES	Vacuum and pressure can vary -/+ 5% of calibrated specification between individual pumps
PUMP FLOW	Flow can only be in one direction and can not be reversed

STANDARD MODELS (Part number)

Xavitech can provide a number of pre-calibrated standard models. With the models the voltage and the max flow is calibrated to a standard value. The only thing that needs to be defined before the pump can be ordered is the lifetime of the pump. The chart below is the standard pumps models that Xavitech can offer. But custom calibration is also an option, please contact Xavitech for more information:

MODEL	VOLTAGE (DC)	CALIBRATED FLOW (ml/min)	MAX PRESSURE (mbar)	CONNECTION INTERFACE	ANALOG FLOW CONTROL	SERIAL INTERFACE (RS-232)	LIFE TIME (Hours)
P1500-BF12V	12V	1300	>300	Flex cable	YES	YES	2000 to 35 000
P1500-BF24V	24V	1400	>350	Flex cable	YES	YES	2000 to 35 000
P1500-B3C12V	12V	1300	>300	3 Wires	YES	NO	2000 to 35 000
P1500-B3C24V	24V	1400	>350	3 Wires	YES	NO	2000 to 35 000
P1500-B5C12V	12V	1300	>300	5 Wires	YES	YES	2000 to 35 000
P1500-B5C24V	24V	1400	>350	5 Wires	YES	YES	2000 to 35 000

Read more about how to control the pump flow with either analog signal or with serial interface and how to chose your custom calibration point in dedicated instructions at www.xavitech.com.

P1500 BLACK edition. 12V DC version

Calibrated freeflow Vs. Current (@ 12V DC)

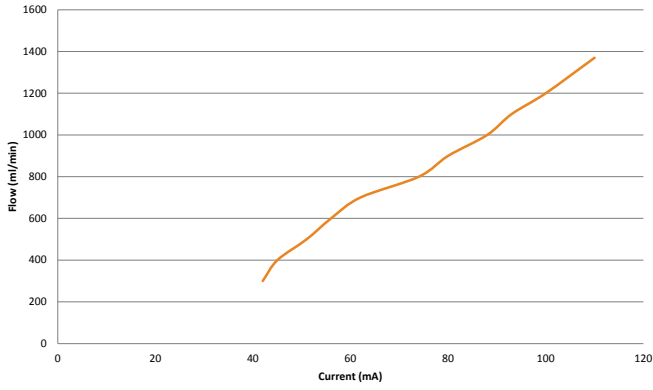

Flow Vs. Pressure (@ 12V DC)

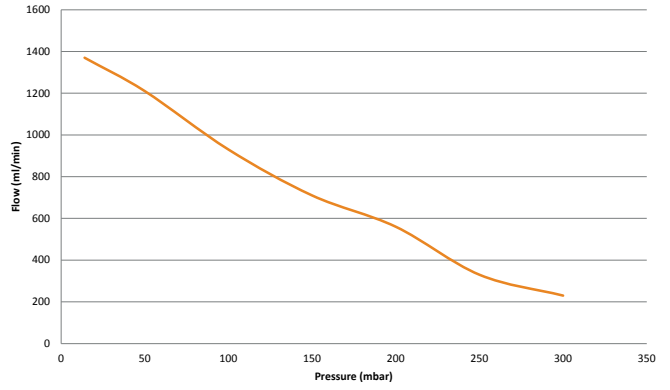

Pressure Vs. Current (@ 12V DC at maximum freeflow)

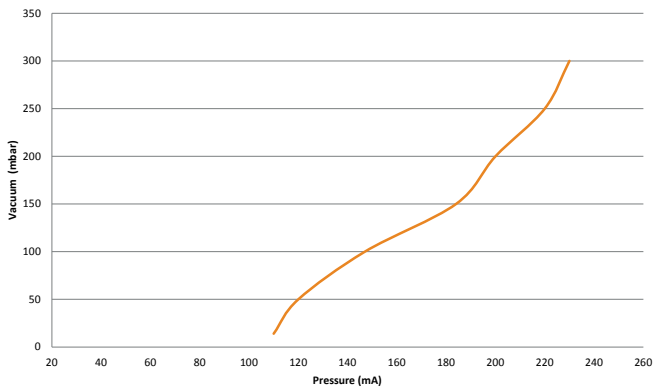

P1500 BLACK edition. 24V DC version

Calibrated freeflow Vs. Current (@ 24V DC)

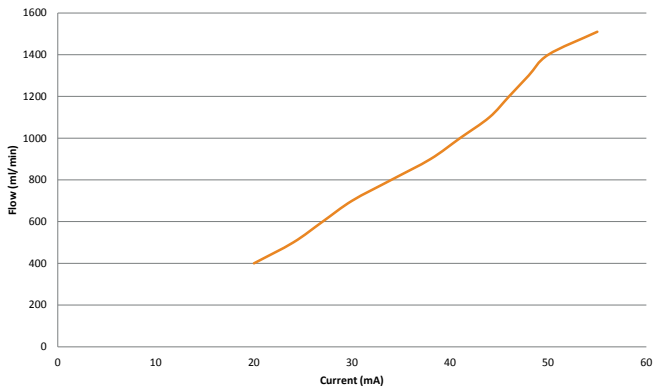

Flow Vs. Pressure (@ 24V DC)

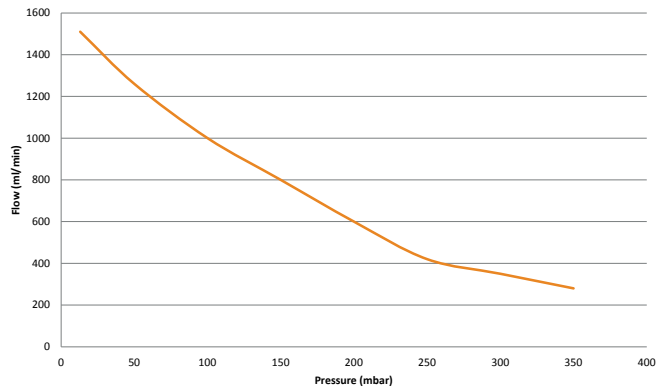

Pressure Vs. Current (@ 24V DC at maximum freeflow)

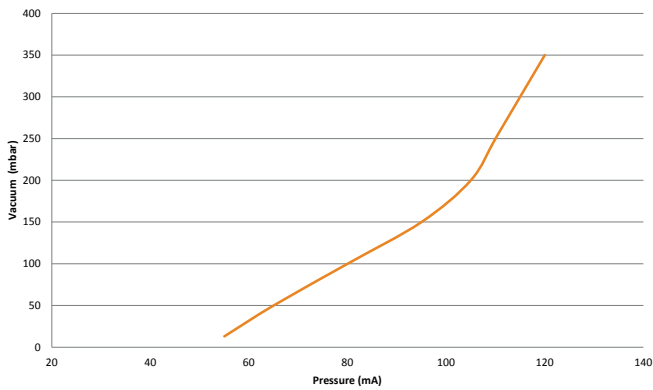

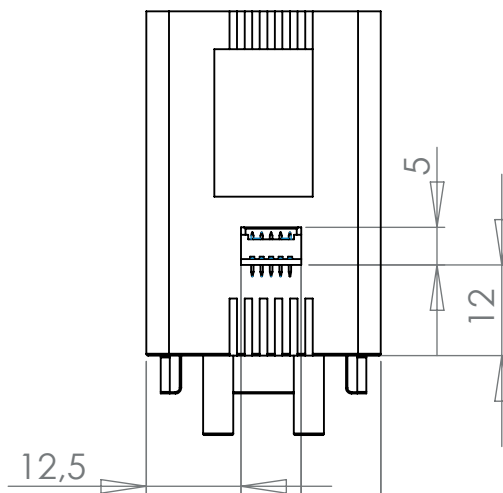
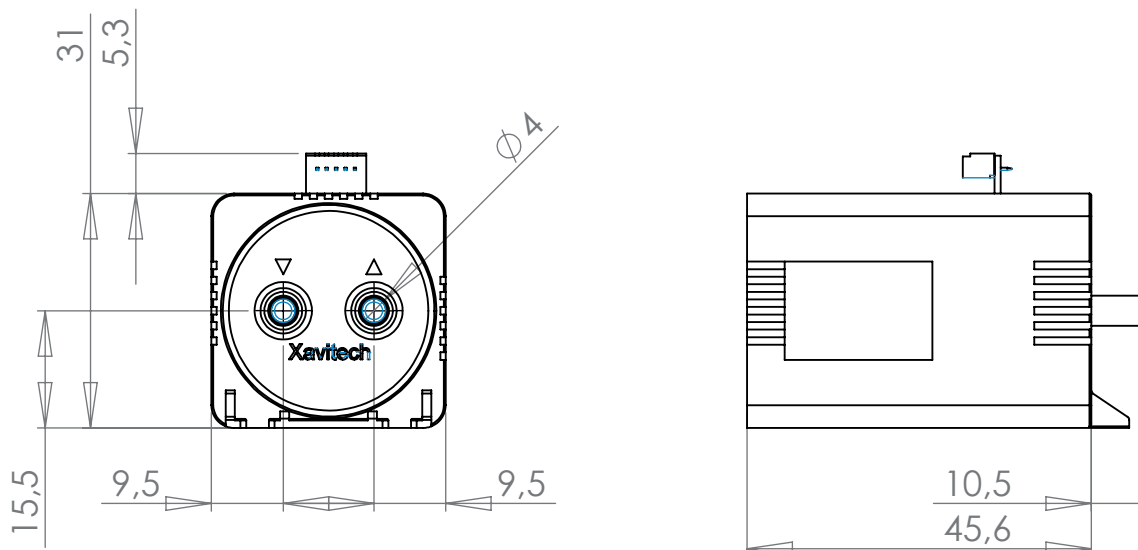

ALL DIMENSIONS ARE IN MM

PUMP MODEL	V1500 AND P1500 ORANGE EDITION
CONNECTION	2 wires
DRAWING SCALE	1:1
DIMENSION TOLERANCE	+/- 0,4mm
PUMP WEIGHT	108g +/- 2g
RECOMMENDED CONNECTORS	MOLEX 53047 (picoblade)
RECOMMENDED TUBE ID	2,8 - 3,8mm (Material dependent)

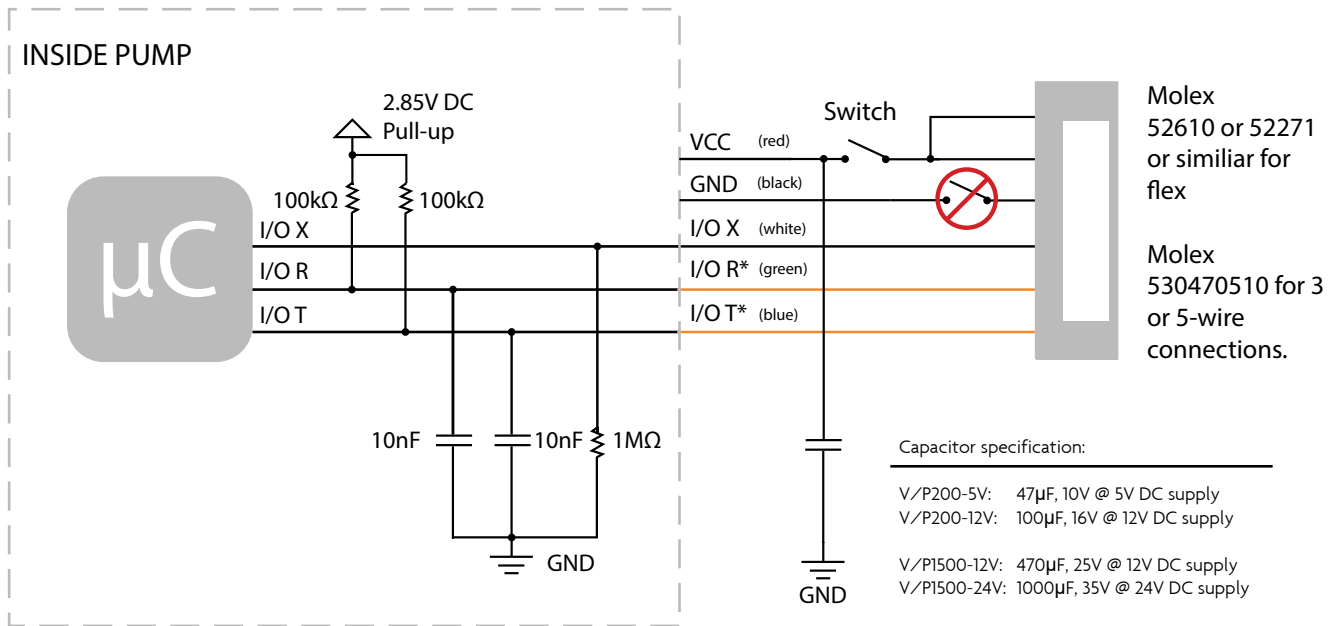

* Serial interface applies on pump with FLEX or 5 wire connection

INTERFACE DESCRIPTION

VCC (SUPPLY VOLTAGE)

Each pump model is calibrated to run on at least one input voltage from the range of 3.2 to 24 V DC. Supply voltage can be customized for each customer need.

Max input voltage: Calibrated voltage +0.1V DC. Pump can be damaged otherwise.

Min input voltage: 3.2 V DC. However, Pump performance is reduced if voltage is reduced from the calibrated voltage. Xavitech recommends to always run the pump on the calibrated voltage.

Image 2 shows in terms of current consumption a typical pump stroke cycle. Since the motor of Xavitech pumps is based on an electromagnet a negative current will occur when the electromagnet is turned off. (you can read more about this in the principle of operation document)

It is because of this current a capacitor between VCC and GND is needed.

If your system can't handle this spike generated by the electromagnet a schottky diode (flyback diode) can be used instead of the capacitor.

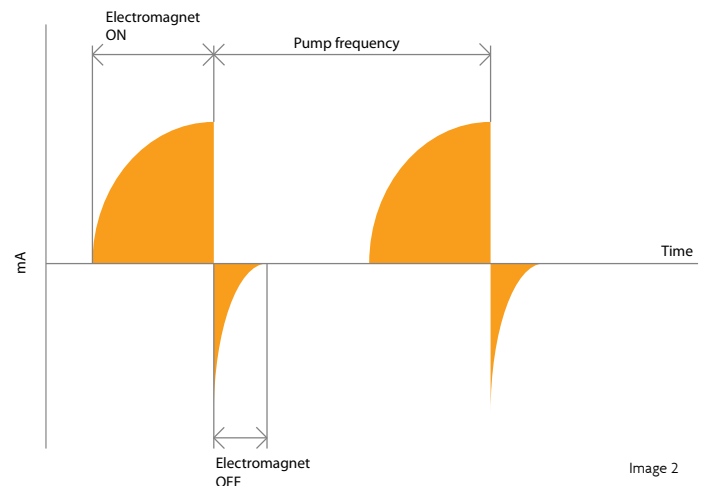

Image 2

I/O X

This is a general I/O connected to a A/D converter of the microcontroller inside the pump.

Default functionality is frequency control.

0 - 0.05V DC Max frequency of the pump.

0.06 to 2.75V DC Frequency control of the pump.

2.75 to 2.85V DC Pump stops

Max input voltage: 3.3 V DC (pump can be damaged if this is exceeded)

Note that the frequency adjustment can only lower the frequency from the factory default frequency. Normally a pump is calibrated to have its max frequency (max flow) set as default at factory.

The use of I/O X can be customized for each customer's need. I/O X can be an analog input, digital input or output. Please contact a Xavitech representative for more information.

I/O R

This connector is connected to the Receive pin of the internal microcontroller UART. Note that a pull-up voltage of 2.85V DC is applied.

The serial interface uses RS-232 with TTL levels of 2.85V DC. Maximum rating of this connector is 3.3V DC.

Read more about this in documentation for the pump serial interface.

I/O T

This connector is connected to the Transmit pin of the internal microcontroller UART. Note that a pull-up voltage of 2.85V DC is applied.

The serial interface uses RS-232 with TTL levels of 2.85V DC. Maximum rating of this connector is 3.3V DC.

Read more about this in documentation for the pump serial interface.

SWITCH THE PUMP ON AND OFF

There are many ways that you can turn the pump on and off. But Xavitech recommends these three options.

1) Via the I/O X connector. apply a voltage of at least 2.75V DC (max 3.3V DC) and the pump will stop. The pump will start within a few mS (depending on what frequency the pump is calibrated in default) when a voltage lower than 2.75V DC is applied. However, note that the internal microcontroller will still run so the pump will consume <10mA.

2) Via the serial interface. Use the specific STOP command and the pump will stop. Then use the RESET command to start the pump. Note that the microcontroller now will perform the start-up procedure which takes up to <3s (depending on default pump frequency). During this time the pump adjusts the stroke length to reach its calibrated length. The regulation adjusts the stroke length for every pump stroke thus it depends on the pump frequency.

Note that the internal microcontroller will still run so the pump will consume <10mA.

3) Switch power on and off. Note that the power has to be switched off on the supply connector (see image 1) and that the capacitor has to be placed between the pump and the switch. This is due to the current that the electromagnet generates. Pump will be damaged if the switch is placed on the ground connector.

The pump will in this case not consume any power but the microcontroller will perform the start-up procedure which takes up to <3s (depending on default pump frequency) when the power is turned on. During this time the pump adjust the strokelenght to reach it's calibrated length. The regulation adjusts the strokelength for every pumpstroke thus it depends on the pump frequency.

MOTOR SPECIFICATION

Xavitech can customized the motors for customers, but for the standard pump models the following values are the specifications for the electromagnets in those pumps.

	V/P200-5V Versions	
Inductance:	14.2mH	
Impedance:	5.8ohm	
	V/P200-12V Versions	V/P1500-12V and 24V Versions
Inductance:	36mH	29.5mH
Impedance:	14.2ohm	5.8ohm

CAPACITOR SPECIFICATIONS

Xavitech recommend to us a capacitor parallel to the power supply (see image above) in order to reduce the power spikes generated by the electromagnetical driven motor. See information below of the recommended sizes of capacitors.

V200-5V Pumps	47µF, 10V
V200-12V Pumps	100µF, 16V
P200-5V Pumps	47µF, 10V
P200-12V Pumps	100µF, 16V
V1500-12V Pumps	470µF, 25V
V1500-24V Pumps	1000µF, 35V
P1500-12V Pumps	470µF, 25V
P1500-24V Pumps	1000µF, 35V

COMMUNICATION SETTINGS

Asynchronous communication, 9600 baud, 8bit, 1 start bit, 1 stop bit, no parity
Voltage level: 2,85V DC (Max 3,3V DC)

SERIAL PROTOCOL

Communication package:

$\langle SNHi \rangle \langle SNMi \rangle \langle SNLo \rangle \langle NetID \rangle \langle ADRHi \rangle \langle ADRLo \rangle \langle R/W-AMOUNT \rangle \langle DATA1 \rangle \langle DATAx \rangle \langle CHKSM \rangle$

Pump serial number: $\langle SNHi \rangle \langle SNMi \rangle \langle SNLo \rangle$

Pump serial number, if you wish to address a pump in a system with more than one pump these values can be set from 1 – 16777215. However, the general call is 0 which will be default.

Pump netId: $\langle NetID \rangle$

Can also be used to address single pumps with a value from 1-255. 0 will be used as general call and that is also the default value.

Memory address (EEPROM and RAM): $\langle ADRHi \rangle \langle ADRLo \rangle$

ADRH_i uppermost 2 bits is setting for which memory type to access. Lower 6 bits of ADRH_i and ADRL_o byte forms the memory address.

ADRH_i=00XXXXXX=RAM

ADRH_i=01XXXXXX=EEPROM

Memory address pointer=(ADRH_i AND 00111111)*256+ADRL_o

Amount of data: $\langle R/W-AMOUNT \rangle$

Number of bytes to read or write to either the RAM or the EEPROM

$\langle R/W-AMOUNT \rangle = 00XXXXXX =$ Read from memory

$\langle R/W-AMOUNT \rangle = 10XXXXXX =$ Write to memory

Number of bytes to read/write is the lower 6bits + 1. So if you want to read 1byte the lower 6 bits should be 0 (0+1=1), if they are set to 63 (bin XX111111) you will read 64bytes (63+1=64).

Data bytes: $\langle DATAx \rangle$

Number of databytes defined in $\langle R/W-AMOUNT \rangle$.

Package checksum: $\langle CHKSUM \rangle$

Add every byte in the package (without carry/overflow) to calculate checksum.

Response from pump:

If a read command is sent to the pump a 3 byte response will be sent. The pump will at least send an integer value and a checksum. Number of bytes is defined by the chosen amount data.

<DATA1><DATAx><CHKSUM>

If a write command is executed the pump will answer <165> if the command was successful executed and <90> if it failed.

SERIAL COMMANDS

Flow control (pump frequency adjustment):

The pump frequency, and thus the flow, can be changed independently of the applied voltage. This is an important feature that enables flow control independently of supply voltage and thus a lower flow can be achieved without reducing maximum vacuum/pressure. This also reduces current consumption and the need of flow restrictors. It is both costeffective and power efficient.

Command package:

<0> <0> <0> <0> <1> <126> <129> <Lo Byte> <Hi Byte> <CHKSM>

The frequency is defined as a 16-bit number and is actually a delay time between each new pump stroke.

Highest frequency/highest flow: 16-bit number = 0 (Default calibrated flow)

Lowest frequency/lowest flow: 16-bit number = 65 535

Example:

<0> <0> <0> <0> <1> <126> <129> <232> <3> <235>

16-bit value = 1000

Response of command was successfully written: <165>

Read firmware: *<0><0><0><0><192><0><1><0><0><193>*

Get the firmware version of the pump. 1 byte with the checksum of entire flash will be sent from the pump.

Stop pump:

First: *<0><0><0><0><0><122><129><0><0><251>*

wait for <165>

Then: *<0><0><0><0><0><37><129><0><0><166>*

wait for <165>

Reset pump: *<0><0><0><0><128><0><1><0><0><129>*

Pump start with initial start up process.