



SiC - photodiode JEC 0,3 E



- characteristics :**
- ◆ SiC-photodiode with integrated special filter
 - ◆ response approximately (CIE 87)
 - ◆ optimized for solar application
 - ◆ hermetically sealed package

- applications :**
- ◆ UV-measurement only
 - ◆ measurement of erythema efficient UV-part on natural sunlight

Absolute maximum ratings :

reverse voltage 20 V
 operating temperature range - 25 °C ... 70 °C
 storage temperature range 0 °C ... 100 °C
 welding temperature (3s) 260 °C

technical data :

common test conditions if not otherwise specified: T_A = 25 °C, V_R = 0 V

parameters	test condition	min.	typ.	max.	unit
active area			0,22		mm ²
chipsize			0,5x0,5		mm ²
max. spectral responsivity	S = S _{max}	0,075	0,1	0,13	A/W
absolute spectralresponsivity	λ = 312 nm		0,008		A/W
Dark current I _R	V _R = 1 V		10		fA
capacitance			80		pF

relative spectrale responsivity

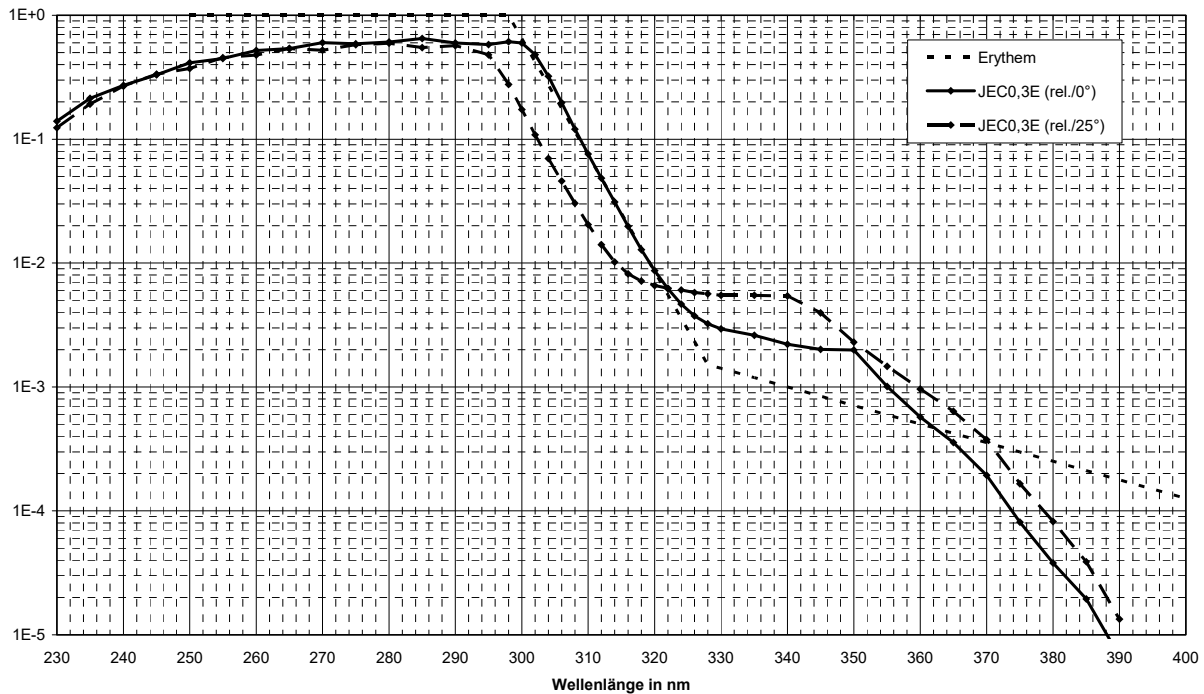

package dimension

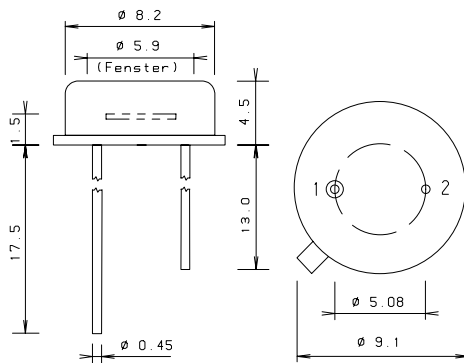

- 1 Kathode
- 2 Anode & Case

application example

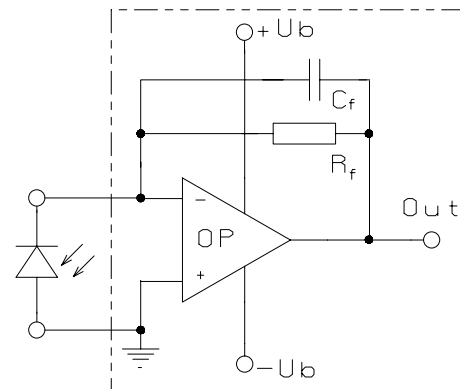

The application example shows a typical electrical application circuit.

R_f determines responsivity of the circuit, typical values are 100 MOhm to 1 GOhm.

C_f works as compensation of junction capacity of the photodiode and input capacity of the OP-amplifier.

Exact value of C_f depends on R_f , used OP-Amp as well as the parasitic capacities of the electrical circuit, typical value is 1 pF at minimum. For static measurements (UVI) C_f can be chosen much higher (1nF), so an additional effective suppression of noise of the amplifier can be achieved..

