



Electro Optical Components, Inc.

5460 Skylane Boulevard, Santa Rosa, CA 95403

Toll Free: 855-EOC-6300

www.eoc-inc.com | info@eoc-inc.com



CASING MATERIAL: AEROSPACE GRADE ALUMINIUM ALLOY
FINISH: BLACK ANODISED

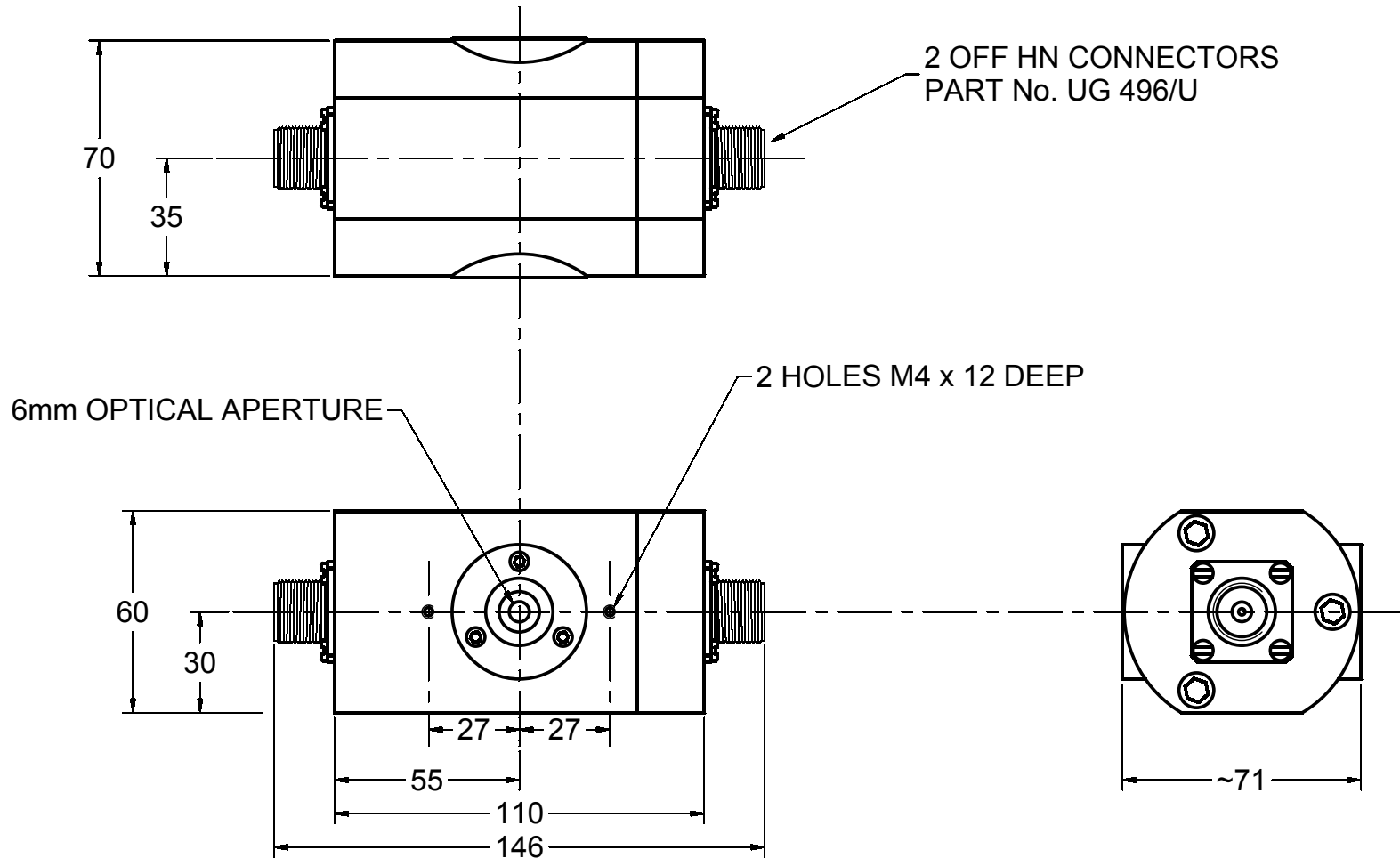

LEYSOP

ULTRA FAST POCKELS CELL (UPC)
INTERFACE DIAGRAM

Scale
1:2

Drawn
S. PAYNE

Approved
P. FRANKS

Issue
1

Date
07/06/02

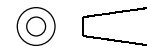

Drawing No.
82 Part 7

Dims.
mm

Tolerances Unless
Otherwise Stated

±0.1