

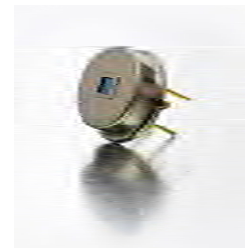

## One Channel Pyroelectric Low Noise Detector PS1x1C2-A-S1.5

Pyroelectric one-channel current mode detector for NDIR gas analysis with bipolar low noise circuit.

Active Area	0.8 x 0.8	mm <sup>2</sup>
Aperture	1.5 x 1.5	mm <sup>2</sup>
Mode	Current	
Time Constant $t_{(0-63\%)} \text{ thermal}$	typ. 17	ms
Time Constant $t_{(0-63\%)} \text{ electrical}$	typ. 2.7	ms
AC Sensitivity <sup>1,2,3</sup>	typ. 175000	V/W
Noise Density Voltage <sup>1</sup>	typ. 50	$\mu\text{V}/\text{Hz}^{1/2}$
Noise Equivalent Power NEP <sup>1,2,3</sup>	typ. $2.86 \times 10^{-10}$	W/Hz <sup>1/2</sup>
Specific Detectivity $D^* \text{ }^{1,2,3}$	typ. $2.8 \times 10^8$	cmHz <sup>1/2</sup> /W
Microphonic Voltage <sup>1</sup>	typ. 2500	$\mu\text{V}/\text{g}$
Filling Gas	Kr	
Filters	All Micro-Hybrid standard narrow band pass filters can be combined. Customized filters on request. For more information please see document "infrared filters"	
Operation Voltage VDD+	$\pm 2.2 \dots \pm 8$	VDC
Operation Current	max. 0.07	mA
Feedback Resistor	10	GOhm
Feedback Capacitor	275 $\pm$ 55	fF
Operation Temperature	-25 ... +85	°C
Mass	~1	g
Housing	T039 (modified)	



### Equivalent Circuit

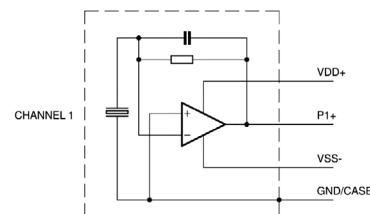

### Pin Assignment

#### Bottom View

- Pin 1 VSS-
- Pin 2 VDD+
- Pin 3 Output P1+
- Pin 4 GND

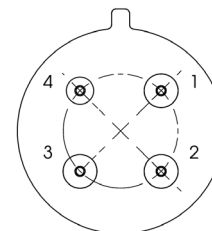

<sup>1</sup> at T<sub>amb</sub>=25 °C, 10 Hz, band width 1 Hz

<sup>2</sup> Blackbody T=500 K; E=38 W/m<sup>2</sup>

<sup>3</sup> on air without windows

# One Channel Pyroelectric Low Noise Detector PS1x1C2-A-S1.5



## Frequency Response

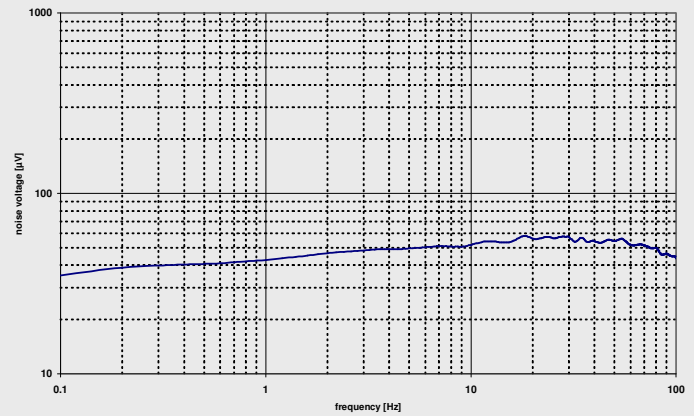
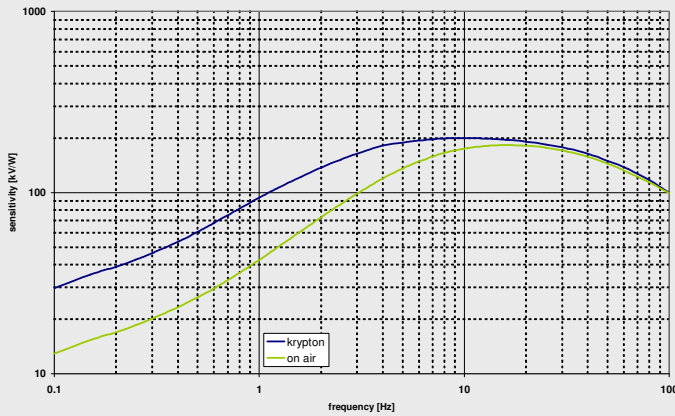

## Housing

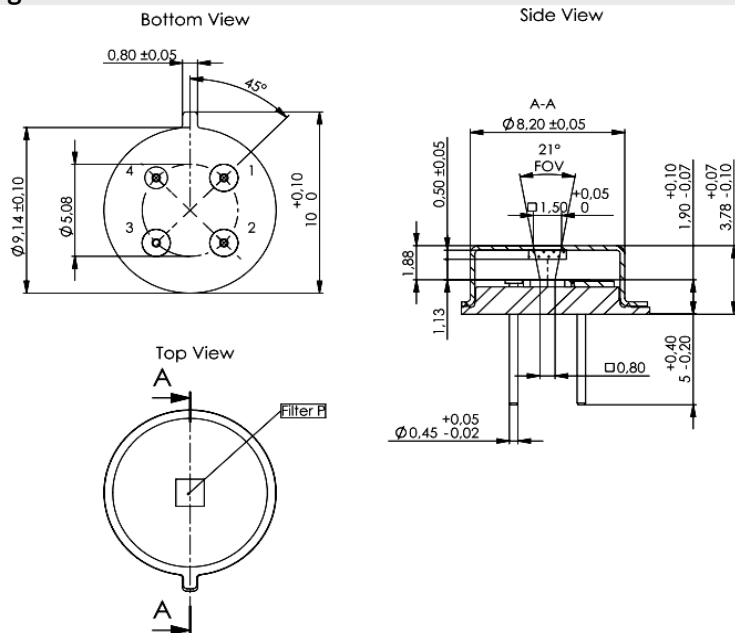

## Ordering Information

PS1x1C2-A-S1.5-Filling Gas (GG)-Filter (H)

e.g. PS1x1C2-A-S1.5-Kr-E1

## Optional parts

IR-Source JSIR 350 - Fast IR emitter based on thin film technology  
Art.-Nr. 6353.01-3.01

Evaluation Kit - For independent evaluation of emitters and detectors  
Art.-Nr. 7206.01-A.00