



Two Channel Pyroelectric Low Noise Detector PS2x1C2-A-S1.5

Pyroelectric dual-channel current mode detector for NDIR gas analysis with bipolar low noise circuit.

Active Area	2 x (0.8 x 0.8)	mm ²
Aperture	2 x (1.5 x 1.5)	mm ²
Mode	Current	
Time Constant $t_{(0-63\%)} \text{ thermal}$	typ. 17	ms
Time Constant $t_{(0-63\%)} \text{ electrical}$	typ. 2.7	ms
AC Sensitivity ^{1,2,3}	typ. 175000	V/W
Noise Density Voltage ¹	typ. 50	$\mu\text{V}/\text{Hz}^{1/2}$
Noise Equivalent Power NEP ^{1,2,3}	typ. 2.86×10^{-10}	W/Hz ^{1/2}
Specific Detectivity $D^* \text{ }^{1,2,3}$	typ. 2.8×10^8	cmHz ^{1/2} /W
Microphonic Voltage ¹	typ. 2500	$\mu\text{V}/\text{g}$
Filling Gas	Kr	
Filters	All Micro-Hybrid standard narrow band pass filters can be combined. Customized filters on request. For more information please see document "infrared filters"	
Operation Voltage VDD+	$\pm 2.2 \dots \pm 8$	VDC
Operation Current	max. 0.07	mA
Feedback Resistor	10	GOhm
Feedback Capacitor	275 \pm 55	fF
Operation Temperature	-25 ... +85	°C
Mass	~1	g
Housing	T039 (modified)	

¹ at T_{amb}=25 °C, 10 Hz, band width 1 Hz

² Blackbody T=500 K; E=38 W/m²

³ on air without windows

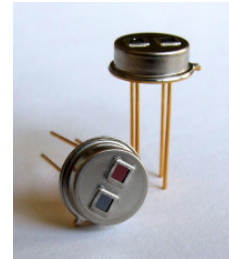

Equivalent Circuit

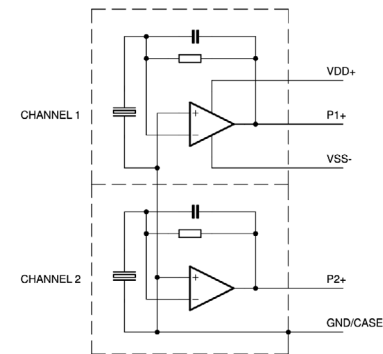

Pin Assignment

Bottom View

- Pin 1 Output P1+
- Pin 2 VDD+
- Pin 3 Output P2+
- Pin 4 VSS-
- Pin 5 GND

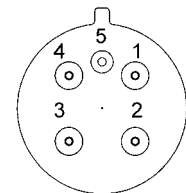

Two Channel Pyroelectric Low Noise Detector PS2x1C2-A-S1.5



Frequency Response

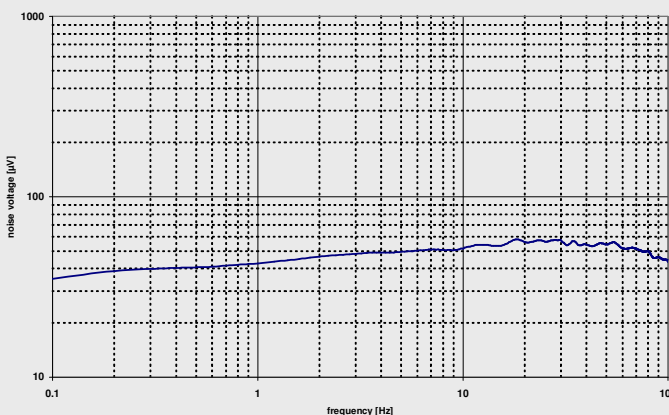
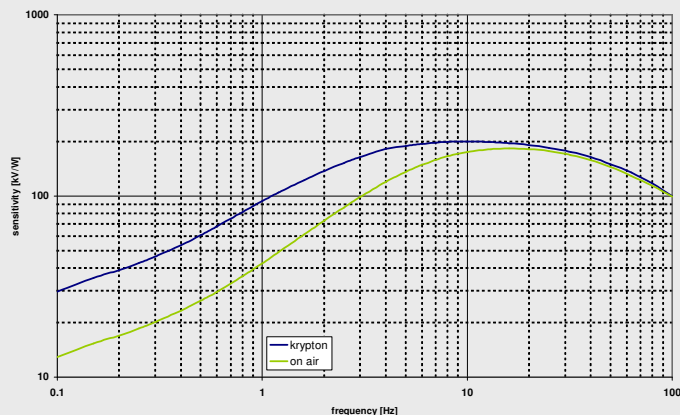

Housing

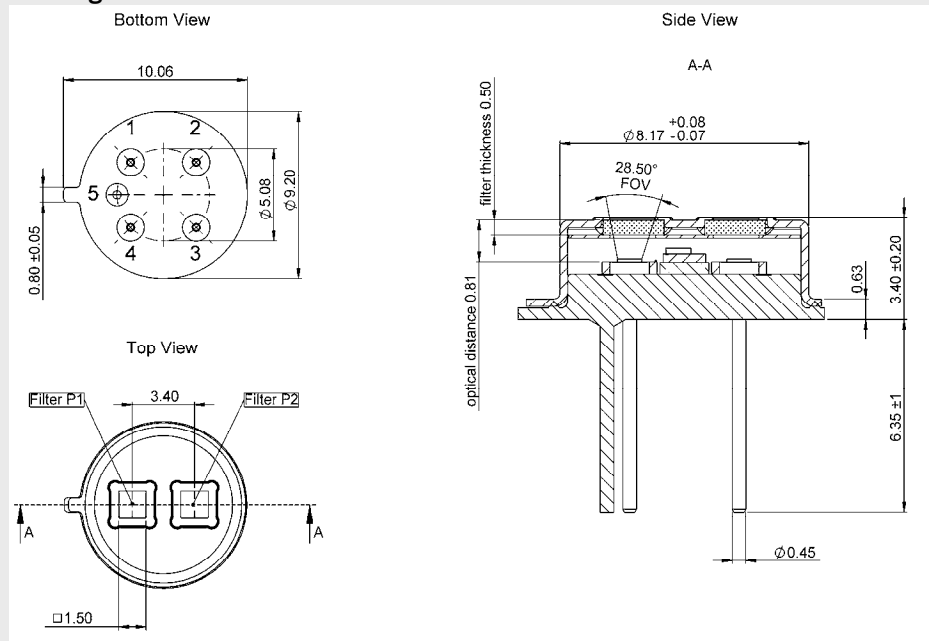

Ordering Information

PS2x1C2-A-S1.5-Filling Gas (GG)-Filters (H/H)

e.g. PS2x1C2-A-S1.5-Kr-E1/D1

Optional parts

IR-Source JSIR 350 - Fast IR emitter based on thin film technology
Art.-Nr. 6353.01-3.01

Evaluation Kit - For independent evaluation of emitters and detectors
Art.-Nr. 7206.01-A.00