



One Channel Thermopile Detector TS1x200B-A-D3.55

High sensitive thermopile detector based on thin film technology for NDIR gas analysis.

Active Area	1.2 x 1.2	mm ²
Aperture	Ø 3.55	mm
Number of Thermocouples	200	
Time Constant $\tau_{(0-63\%)}^1$	typ. 30	ms
DC Output Voltage ¹	typ. 5.5	mV
DC Sensitivity ¹	typ. 100	V/W
Temperature Coefficient of Sensitivity ²	typ. -0.4	%/K
Noise Voltage ³	typ. 33	nV/Hz ^{1/2}
Noise Equivalent Power NEP ¹	typ. 0.33	nW/Hz ^{1/2}
Specific Detectivity D* ¹	typ. 3.6 x 10 ⁸	cmHz ^{1/2} /W
Resistance of Thermopile ³	65 ± 15	kΩ
Temperature Coefficient of Resistance ²	typ. -0.03	%/K
Thermistor ⁴	1 - PTC 1 kOhm 2 - NTC 30 kOhm 3 - NTC 100 kOhm Technical specifications see document "thermistors".	
Filling Gas ⁵	N ₂ / Kr	
Filters	Micro-Hybrid standard narrow band pass filters and more information please see document "infrared filters". Customized filters possible on request.	
Operation Temperature	-20 ... +70	°C
Mass	1	g
Housing	T039 (modified)	

¹ on air without windows, Blackbody T=500 K; E=38 W/m²

² temperature range from +25 to +70 °C

³ at T_{amb}=25 °C

⁴ Modified pin assignment

⁵ In case of Kr-filling increase of DC Output Voltage, DC Sensitivity, Specific Detectivity and Time Constant by the factor 1.8. Decrease of NEP by the same factor. Other gases on customer's

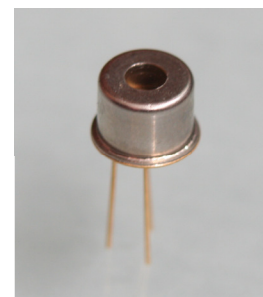

Bottom View

Pin Assignment:

- Pin 1 Output TP-
- Pin 2 Output TP+
- Pin 3 GND

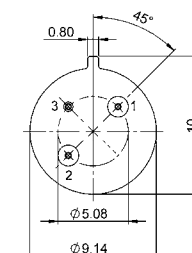

Ordering Information:

TS1x200B-A-D3.55- Thermistor (F) - Backfill

Gas (GG) - Filter (H)

e.g. TS1x200B-A-D3.55-1-Kr-A2



One Channel Thermopile Detector TS1x200B-A-D3.55

Housing
T039 package

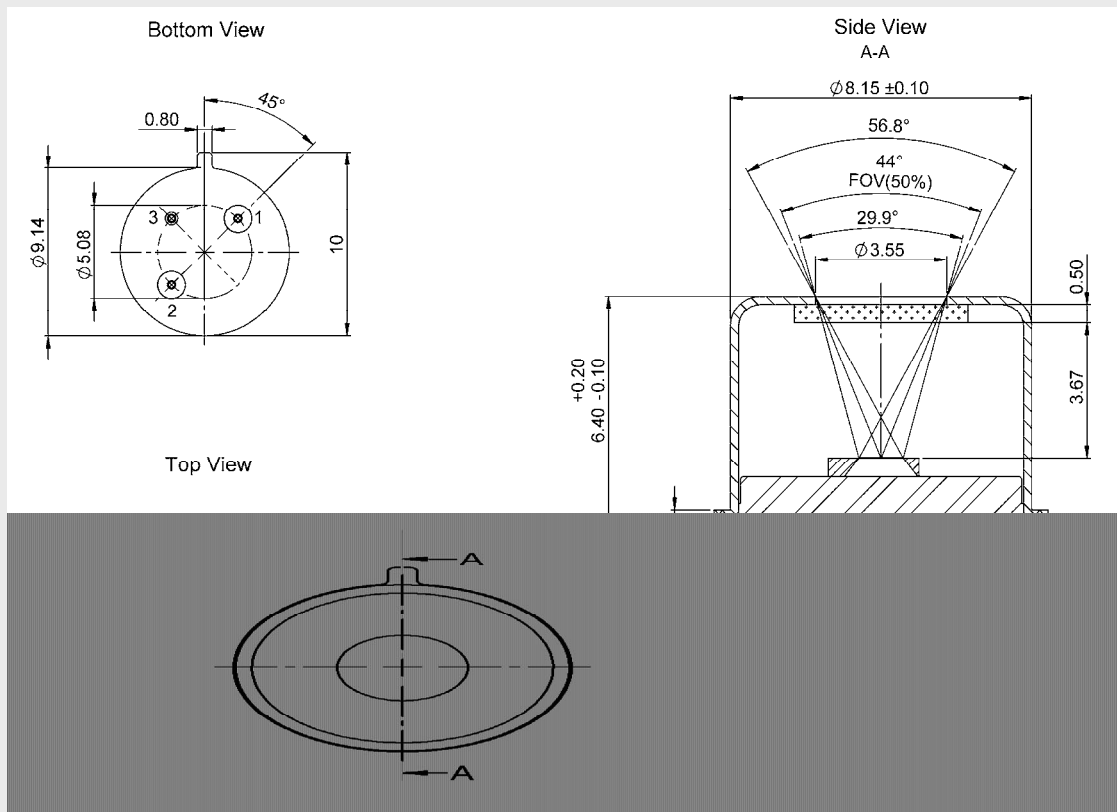

Optional parts:

IR-Source JSIR 350 - Fast IR emitter based on thin film technology
Art.-Nr. 6351.01-3.01

IR-Source JSIR 450 - Broadband IR emitter high performance for heavily absorbing media
Art.-Nr. 6350.01-3.01