



## Datasheet

High Speed, Low Noise Micro Spectrometer

**EOC-SI-2000H**

### FEATURES

- **Frame speed: >1Kfps**
- **Pixel combined to speed up**
- **spectral region: 200-1100 nm**
- **Spectral resolution: 0.1-5 nm**
- **Optical configuration: crossed Czerny-Turner**
- **Linear low noise CMOS detector with 2048 pixel**
- **Integration times: 0.1ms-256s**
- **Supply voltage: DC 5V (USB Power)**
- **16 bit, 2MHz A/D Converter**
- **Interface: USB2.0 (High speed)**
- **20-pin connector for interfacing to external products**

### GENERAL DESCRIPTION

EOC-SI-2000H micro spectrometer is a low noise high-performance, miniature fiber-optic Spectrometer. Its sensor is a 2048 pixel CCD which responds from 200-1100 nm.

EOC-SI-2000H is perfect for fast detection attribute to its high A/D converter frequency and the highspeed data transmission. In EOC-SI-2000H memory chip, some algorithms to improve the performance are programmed solidly, such as wavelength calibration coefficients, linearity coefficients. It output the spectrum data to PC through USB 2.0 or RS232 interface. EOC-SI-2000H operates with a single +5VDC supply supplied from USB or duo-pin interface



# Datasheet

## Specifications

Detector	
Type	Linear array detector
Detectable range	200-1100 nm
Effective pixel	2048
Pixel dimension	14 $\mu$ m $\times$ 200 $\mu$ m
Sensitivity	1300 V/(lx·s)
Dark noise	13 RMS @ 13 °C
Optical Parameter	
Wavelength range	200-1100 nm
Optical resolution	0.2-5 nm
Signal-to-noise	>1800:1
Dynamic range	8.5 x 10 <sup>7</sup> (system); 2000:1 for a single acquisition
Stray light	<0.05% at 600 nm; <0.09% at 435 nm
Working temperature	-25-50 °C
Working humidity	< 90%RH
Optical Configuration	
Optical Design	f/4 crossed asymmetrical Czerny-Turner
Focal Distance	40 mm for incidence / 60 mm for output
Incidence slit	50 $\mu$ m (25, 100 $\mu$ m are optional)
Incident Interface	SMA905 connector
Electrical Parameter	
Integration time	0.1 ms - 256 second
Interfaces	USB 2.0
A/D conversion resolution	16 bit
Supply voltage	DC4.5 to 5.5 V (type @5V)

# Datasheet

Operating current	240mA@Typ.
Storage temperature	-30°C to +70°C
Operating temperature	-25-50 °C
Physics Parameter	
Dimension	102×72×34 mm <sup>3</sup>
weight	0.2 kg
Sealing	Anti-sweat

## 2 Performance



图 1 The noise of EOC-SI-2000H/EOC-SI-2000H (Yellow) vs ATP200 (Black)

# Datasheet

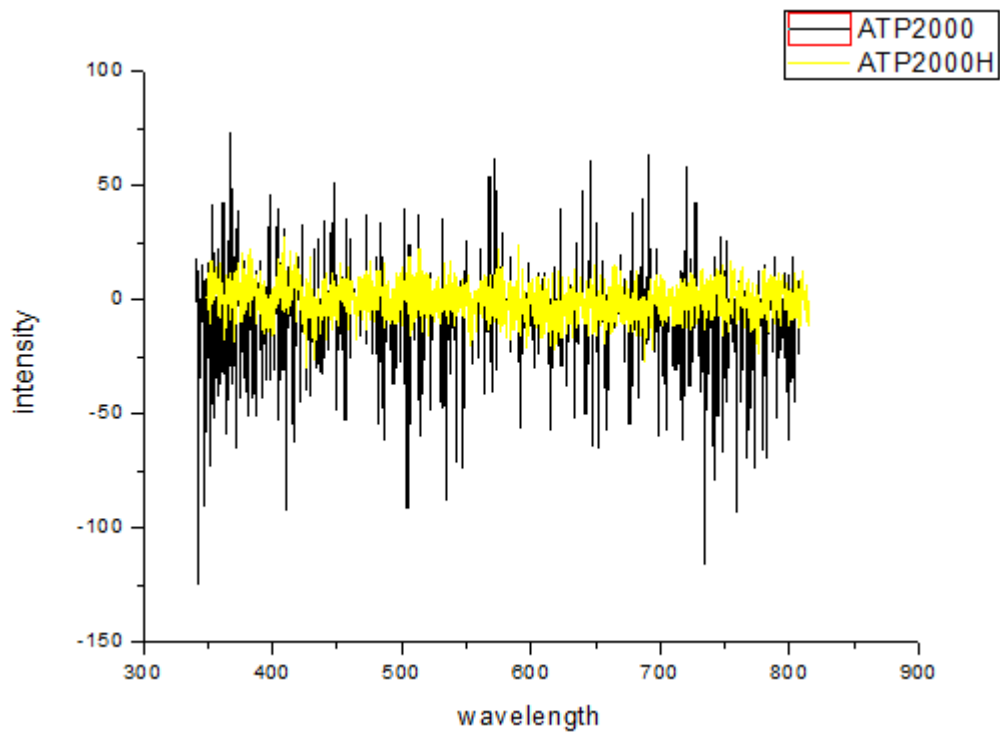

图 2 The sensitive of EOC-SI-2000H/EOC-SI-2000H (Red) vs ATP200 (Black)

# Datasheet

## 3 Mechanical Diagrams

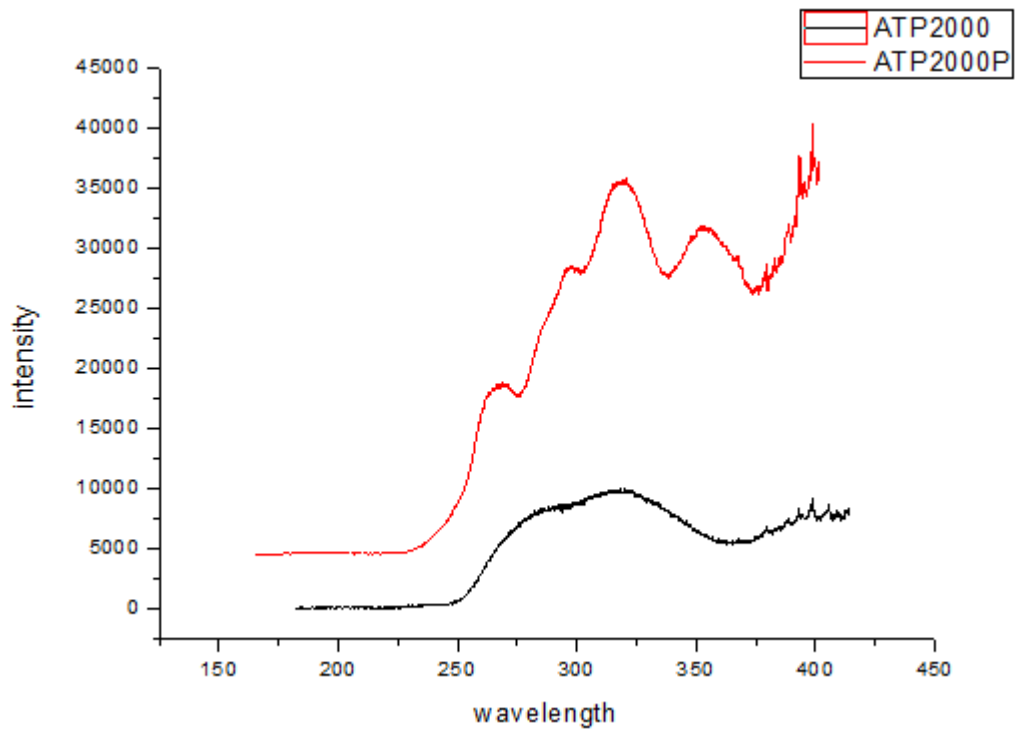
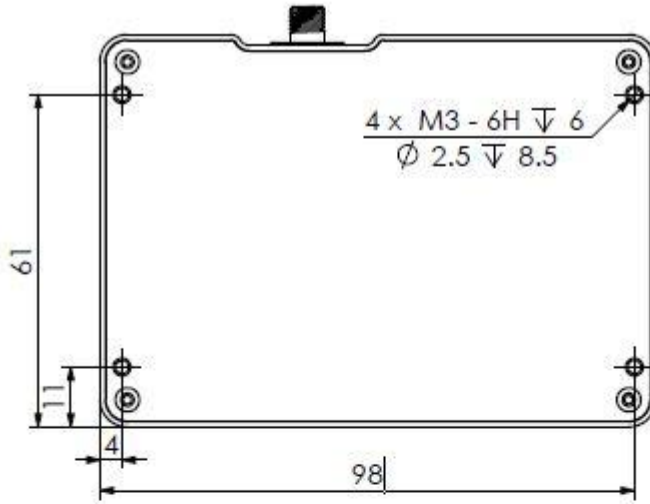

Mounting Holes (M3 X 4)  
固定空位: 4 个 M3 螺孔

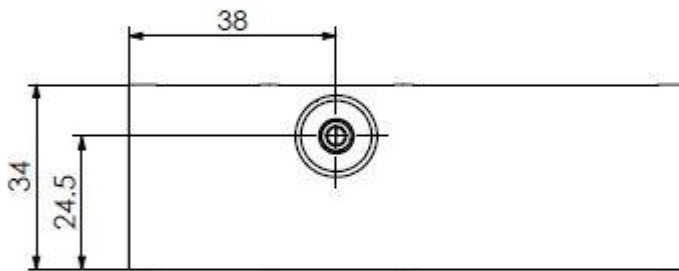

SMA905 Female Fiber interface

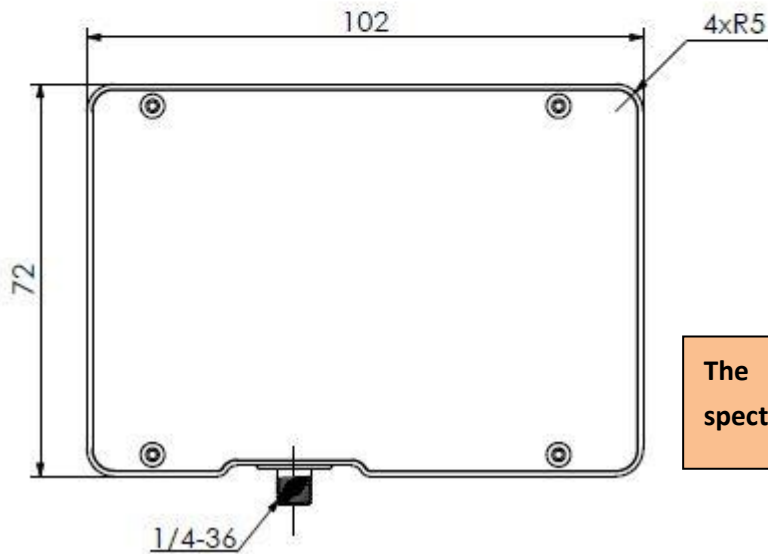

The size of ATP2000 micro spectrometer

# Datasheet

## 4 Electrical Pin-out

Table 1 Electrical Characteristics

Parameter	Min	Typ	Max	Unit
Power Supply				
Operating voltage range	4.5	5	5.5	V
Operating current		170		mA
Logic Inputs(3.3V LVTTL, Five-volt tolerant)				
High level input voltage	1.7		3.6	V
Low level input voltage	-0.3		1.0	V
Logic Output(3.3V LVTTL)				
High level output voltage	2.4			V
Low level output voltage			0.4	V

The module is equipped with a 20-pin male angled box header(2x10, 2.00 mm pitch) and USB2.0 B type interface. The 20-pin connector is a Samtec part # STMM-110-02-L-D-RA connector. The mate to this is a Samtec part # TCSD-10-D-XX.XX-01-N.

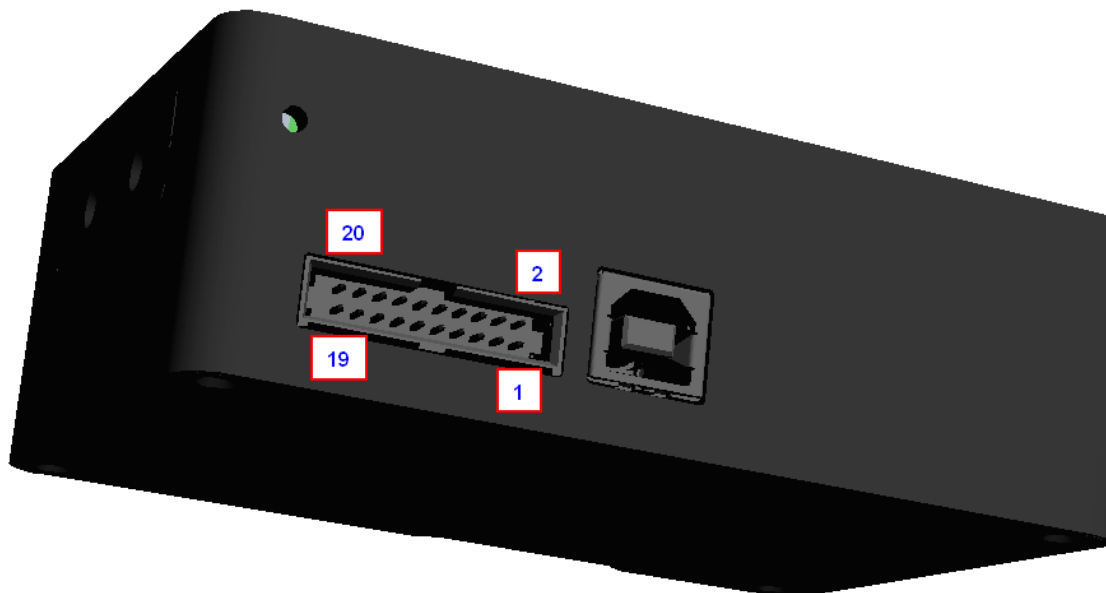

# Datasheet

Table 2 Electrical Pin-Out

Pin#	Description	I/O	Function Description
1	VCC	/	Power Supply, $5V \pm 0.5$ ,
2	GND	/	Ground
3	RS232_TX	Output	RS232 Transmit signal
4	RS232_RX	Input	RS232 Receive signal
5	Lamp_En	Output	LVTTL output the lamp enable signal.
6	Continuous_strobe	Output	LVTTL output the continues strobe signal.
7	Ext_trigger_in	Input	LVTTL input the trigger signal.
8	Single_strobe	Output	LVTTL output the single strobe signal.
9	SPI_SCK	Output	The SPI Clock signal for communications to other SPI peripherals
10	SPI_MOSI	Output	The SPI Master Out Slave In (MOSI) signal for communications to other SPI peripherals
11	SPI_MISO	Input	The SPI Master In Slave Out (MISO) signal for communications to other SPI peripherals
12	SPI_CS	Output	The SPI Chip/Device Select signal for communications to other SPI peripherals
13	GPIO0	Input /Output	General Purpose Software Programmable Digital Inputs/Outputs, LVTTL Logic.
14	GPIO1	Input /Output	General Purpose Software Programmable Digital Inputs/Outputs, LVTTL Logic.
15	GPIO2	Input /Output	General Purpose Software Programmable Digital Inputs/Outputs, LVTTL Logic.
16	GPIO3	Input /Output	General Purpose Software Programmable Digital Inputs/Outputs, LVTTL Logic.
17	GPIO4	Input /Output	General Purpose Software Programmable Digital Inputs/Outputs, LVTTL Logic.
18	GPIO5	Input /Output	General Purpose Software Programmable Digital Inputs/Outputs, LVTTL Logic.

# Datasheet

19	GPIO6	Input /Output	General Purpose Software Programmable Digital Inputs/Outputs, LVTTTL Logic.
20	GPIO7	Input /Output	General Purpose Software Programmable Digital Inputs/Outputs, LVTTTL Logic.

## 5 Order Guide

Order number Rules:

Model	Spectral region		Slit width	
EOC-SI-2000H	Short wavelength	Long wavelength	Slit width	

For example:

What to buy EOC-SI-2000H, spectral region: 200-850nm, slit width is 50 um, then the order no is:

**EOC-SI-2000H-200-850-050**

Order No	Spectral region	Slit	
EOC-SI-2000H-200-400-## #	200~400	10 μm 25 μm	
EOC-SI-2000H-200-850-## #	200~850	50 μm 100 μm	
EOC-SI-2000H-200-1100-## ##	200~1000	200 μm	
EOC-SI-2000H-340-850-## #	340~850	Other: _____μm	
EOC-SI-2000H-600-1100-## ##	600~1100		
EOC-SI-2000H-###-###-## #	Other		



# Datasheet

## 6 Derivation

PN	Description
ATP2000	Basic type
EOC-SI-2000H	The high performance version
EOC-SI-2000H	High speed to 1Kpfs (Real time speed)