



Datasheet

Low Noise Micro Spectrometer

EOC-SI-2000P

FEATURES

- spectral region: 200-1100 nm
- Spectral resolution: 0.2-5 nm
- Optical configuration: crossed Czerny-Turner
- Linear low noise CMOS detector with 2048 pixel
- Integration times: 0.1ms-256s
- Supply voltage: DC 5V (USB Power)
- 16 bit, 2MHz A/D Converter
- Interface: USB2.0 (High speed)
- 20-pin connector for interfacing to external products

APPLICATIONS

- LED spectrophotometer
- Fluorescence
- Biochemical analyzer
- Transmittance detection
- Reflectance detection

GENERAL DESCRIPTION

EOC-SI-2000P micro spectrometer is a low noise high-performance, miniature fiber-optic Spectrometer. Its sensor is a 2048 pixel CCD which responds from 200-1100 nm.

EOC-SI-2000P is perfect for fast detection attribute to its high A/D converter frequency and the high speed data transmission. In EOC-SI-2000P memory chip, some algorithms to improve the performance are programmed solidly, such as wavelength calibration coefficients, linearity coefficients. It output the spectrum data to PC through USB 2.0 or RS232 interface. EOC-SI-2000P operates with a single +5VDC supply supplied from USB or duo-pin interface



Datasheet

Specifications

Detector	
Type	Linear array detector
Detectable range	200-1100 nm
Effective pixel	2048
Pixel dimension	14 μ m \times 200 μ m
Sensitivity	1300 V/(lx·s)
Dark noise	13 RMS @ 13 °C
Optical Parameter	
Wavelength range	200-1100 nm
Optical resolution	0.2-5 nm
Signal-to-noise	>1800:1
Dynamic range	8.5 x 10 ⁷ (system); 2000:1 for a single acquisition
Stray light	<0.05% at 600 nm; <0.09% at 435 nm
Working temperature	-25-50 °C
Working humidity	< 90%RH
Optical Configuration	
Optical Design	f/4 crossed asymmetrical Czerny-Turner
Focal Distance	40 mm for incidence / 60 mm for output
Incidence slit	50 μ m (25, 100 μ m are optional)
Incident Interface	SMA905 connector
Electrical Parameter	
Integration time	0.1 ms - 256 second
Interfaces	USB 2.0
A/D conversion resolution	16 bit
Supply voltage	DC4.5 to 5.5 V (type @5V)
Operating current	170mA@Typ.
Storage temperature	-30°C to +70°C
Operating temperature	-25-50 °C
Physics Parameter	
Dimension	102 \times 72 \times 34 mm ³
weight	0.2 kg
Sealing	Anti-sweat

Datasheet

2 Performance



图 1 The noise of EOC-SI-2000P/ATP2000H (Red) vs ATP2000 (Black)



图 2 The sensitive of EOC-SI-2000P/ATP2000H (Red) vs ATP2000 (Black)

Datasheet

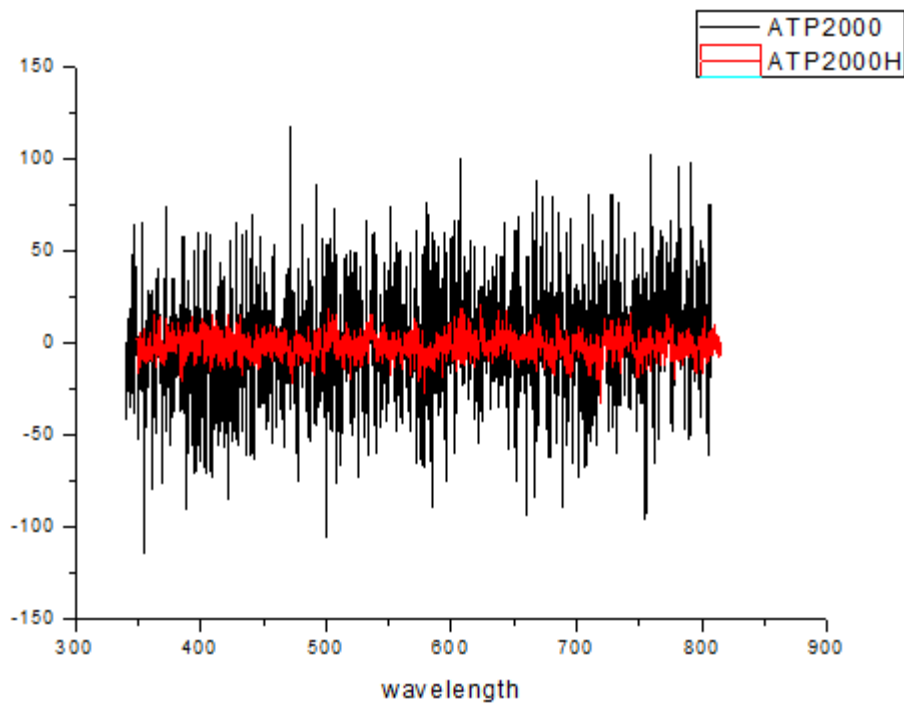
3 Mechanical Diagrams

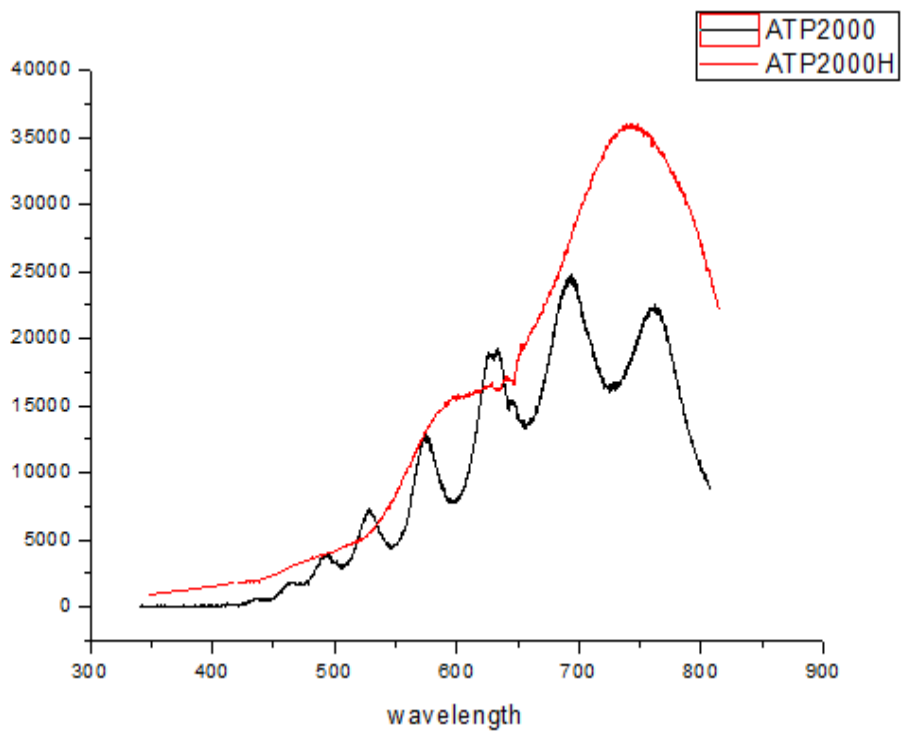
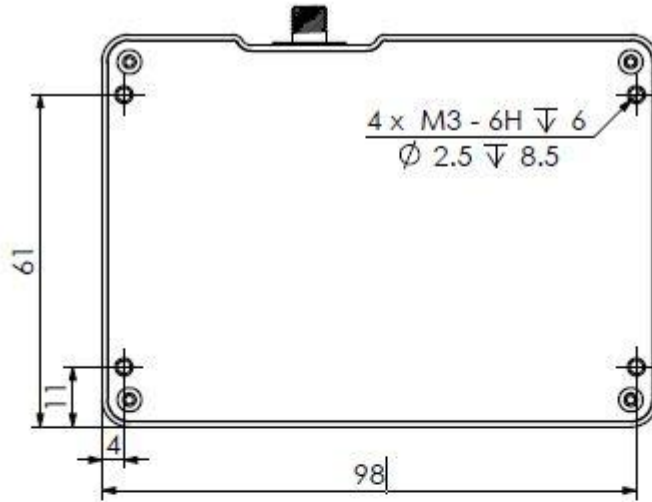

Mounting Holes (M3 X 4)

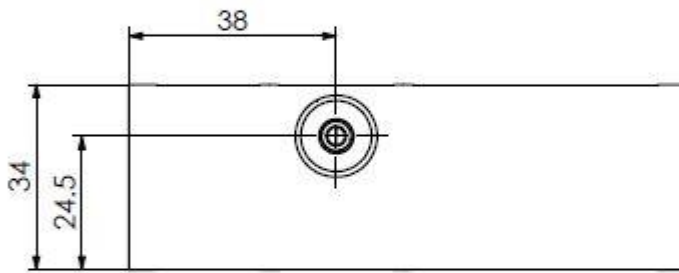

SMA905 Female Fiber interface

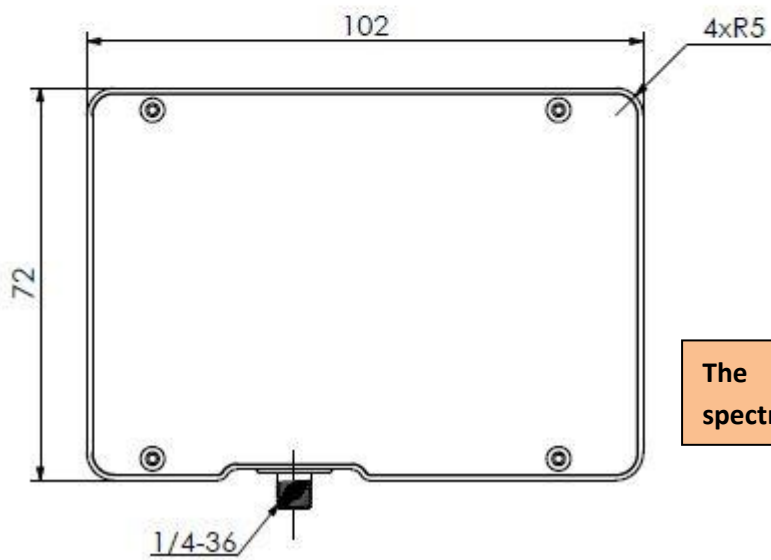

The size of ATP2000 micro spectrometer

Datasheet

4 Electrical Pin-out

Table 1 Electrical Characteristics

Parameter	Min	Typ	Max	Unit
Power Supply				
Operating voltage range	4.5	5	5.5	V
Operating current		170		mA
Logic Inputs(3.3V LVTTL, Five-volt tolerant)				
High level input voltage	1.7		3.6	V
Low level input voltage	-0.3		1.0	V
Logic Output(3.3V LVTTL)				
High level output voltage	2.4			V
Low level output voltage			0.4	V

The module is equipped with a 20-pin male angled box header (2x10, 2.00 mm pitch) and USB2.0 B type interface. The 20-pin connector is a Samtec part # STMM-110-02-L-D-RA connector. The mate to this is a Samtec part # TCSD-10-D-XX.XX-01-N.

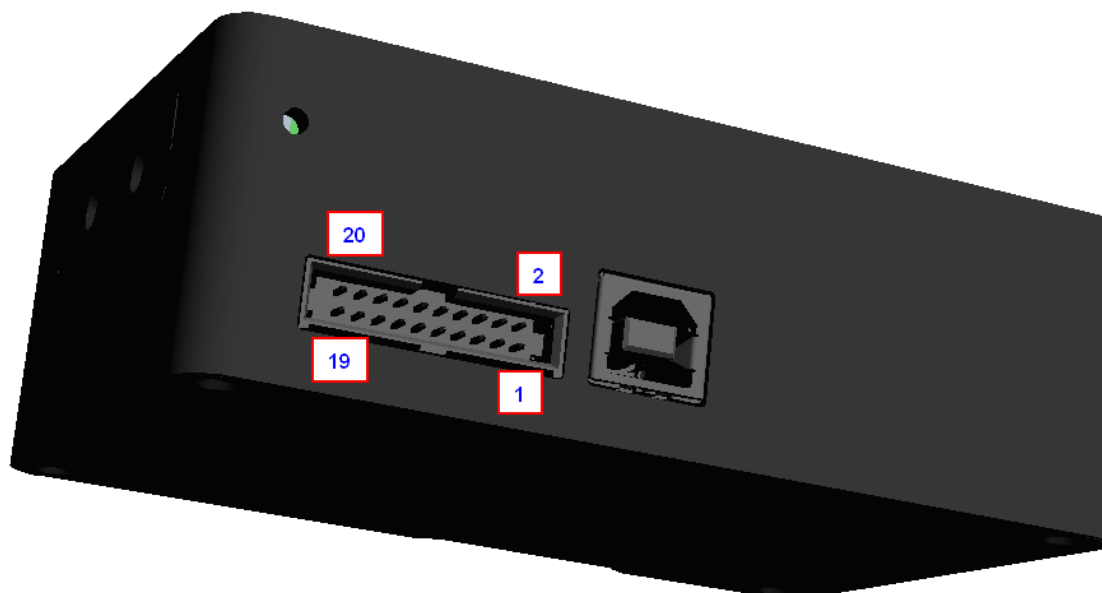

Table 2 Electrical Pin-Out

Pin#	Description	I/O	Function Description
1	VCC	/	Power Supply, 5V ± 0.5,
2	GND	/	Ground
3	RS232_TX	Output	RS232 Transmit signal
4	RS232_RX	Input	RS232 Receive signal
5	Lamp_En	Output	LVTTL output the lamp enable signal.
6	Continuous_stro	Output	LVTTL output the continues strobe signal.

Datasheet

	be		
7	Ext_trigger_in	Input	LVTTL input the trigger signal.
8	Single_strobe	Output	LVTTL output the single strobe signal.
9	SPI_SCK	Output	The SPI Clock signal for communications to other SPI peripherals
10	SPI_MOSI	Output	The SPI Master Out Slave In (MOSI) signal for communications to other SPI peripherals
11	SPI_MISO	Input	The SPI Master In Slave Out (MISO) signal for communications to other SPI peripherals
12	SPI_CS	Output	The SPI Chip/Device Select signal for communications to other SPI peripherals
13	GPIO0	Input /Output	General Purpose Software Programmable Digital Inputs/Outputs, LVTTL Logic.
14	GPIO1	Input /Output	General Purpose Software Programmable Digital Inputs/Outputs, LVTTL Logic.
15	GPIO2	Input /Output	General Purpose Software Programmable Digital Inputs/Outputs, LVTTL Logic.
16	GPIO3	Input /Output	General Purpose Software Programmable Digital Inputs/Outputs, LVTTL Logic.
17	GPIO4	Input /Output	General Purpose Software Programmable Digital Inputs/Outputs, LVTTL Logic.
18	GPIO5	Input /Output	General Purpose Software Programmable Digital Inputs/Outputs, LVTTL Logic.
19	GPIO6	Input /Output	General Purpose Software Programmable Digital Inputs/Outputs, LVTTL Logic.
20	GPIO7	Input /Output	General Purpose Software Programmable Digital Inputs/Outputs, LVTTL Logic.

5 Order Guide

Order number Rules:

Model	Spectral region		Slit width	
EOC-SI-2000P	Short wavelength	Long wavelength	Slit width	

For example:

What to buy EOC-SI-2000P, spectral region: 200-850nm, slit width is 50 μ m, then the order no is:

EOC-SI-2000P-200-850-050

Order No	Spectral region	Slit	
EOC-SI-2000P-200-400-###	200~400	10 μ m	
EOC-SI-2000P-200-850-###	200~850	25 μ m	
EOC-SI-2000P-200-1100-##	200~1000	50 μ m	
#		100 μ m	
EOC-SI-2000P-340-850-###	340~850	200 μ m	

Datasheet

EOC-SI-2000P-600-1100-## #	600~1100	Other: _____μm	
EOC-SI-2000P-###-###-###	Other		

6 Derivation

PN	Description
EOC-SI-2000	Basic type
EOC-SI-2000P	The high performance version <2ms data transfer rate
EOC-SI-2000H	High speed to 1Kpfs