



# UV-Photodiode JEP 11-365

## - preliminary data sheet -

- characteristics :**
- ◆ GaP-Photodiode with integrated filter
  - ◆ spectral range (1% borders) 250 ... 400 nm
  - ◆ active area 10,9 mm<sup>2</sup>

- applications :**
- ◆ flame detection
  - ◆ UV-measurements

### absolute maximum ratings:

reverse voltage	5	V
operating temperature range	- 10...+ 70	°C
storage temperature range	- 25...+ 100	°C
welding temperature (3s)	260	°C

### technical data :

common test conditions, if not otherwise specified:  $\gamma_a = 25\text{ °C}$ ,  $V_R = 0V$

parameter	test conditions	min.	typ.	max.	unit
active area			10,9		mm <sup>2</sup>
spectral range	$S = 0,1 \cdot S_{max}$		250 400		nm
			$\lambda_{min}$ $\lambda_{max}$		
maximum of spectral responsivity $\lambda_p$	$S = S_{max}$		365		nm
absolute spectral responsivity	$\lambda = \lambda_p$		75		mA/W
dark current $I_D$	$V_R = 5\text{ V}$		10	100	pA
rise time fall time of photo current	$R_L = 1\text{ k}\Omega$ $\lambda = 365\text{ nm}$		5		$\mu\text{s}$
capacitance	$f = 10\text{ kHz}$		1000		pF

## absolute spectral responsivity

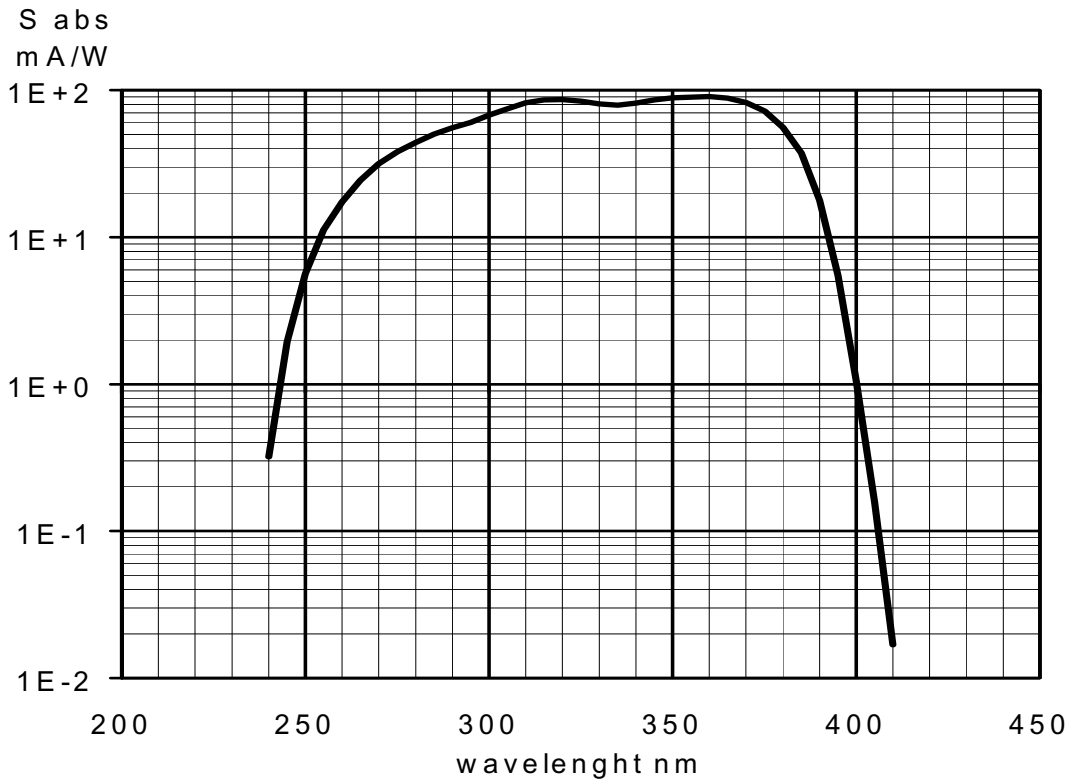

## package dimensions

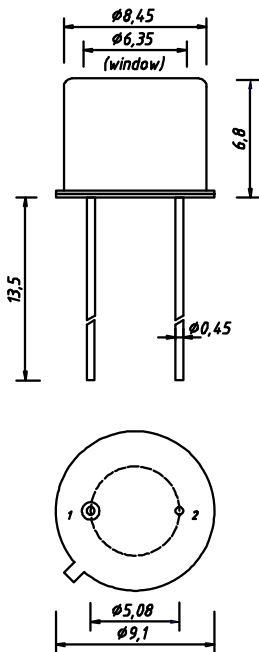

## application

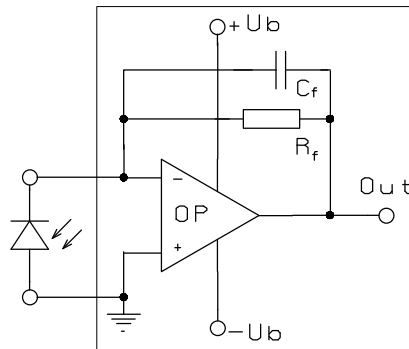

- 1 Anode
- 2 Katode & Case