



JSIR 340-4

Economy MEMS based infrared emitter for cost effective high volume NDIR gas sensing applications like home & building automation.



Applications

- NDIR gas detection
- ATR spectroscopy
- DIR spectroscopy
- PAS spectroscopy

Target gases

- CO₂
- CH₄
- C₃H₈
- C₂H₅OH
- Other infrared active gases

Features

- Cost efficient components
- Standard MEMS technologies
- CMOS compatible manufacturing process
- Effective automatic assembly process with SMD packages
- Hot-plate temperatures up to 740 °C
- Appropriate radiation output
- High modulation depth due to low thermal mass

Additional product information

The combination of MEMS standard hot-plate resistance layer technologies with CMOS compatible manufacturing processes enables the production at high qualified but ordinary MEMS fab production lines.

This is the opener for high volume and cost sensitive applications. The emitter's MEMS chips with focus of cost efficiency and low thermal time constant are developed by our supplier CMOS IR. Despite the focus on mass pro-

duction and mass production applications, the emitter impresses with its high radiant power at hot plate temperatures of up to 740 °C and short time constants.

JSIR 340 sources are available in TO packaging versions with reflector or SMD package. The focus on SMD packages enables an effective automatic assembly process for our customers.

Technical data

Technical parameter	TO39 open	SMD Si ARC	Unit
Spectral output range	2 ... 15	2 ... 15	μm
Active area	2.2 x 2.2	2.2 x 2.2	mm ²
Hot resistant ¹	19 ± 5	17 ± 5	Ω
Temperature coefficient ²	typ. 1 200	typ. 1 000	ppm/K
Time constant _{0-63%}	typ. 13	typ. 11.5	ms
Nominal power consumption ³	650	650	mW
Operation voltage ⁴	typ. 3.5	typ. 3.3	V
Operation current ⁴	typ. 180	typ. 200	mA
Recommended driving mode	Power mode	Power mode	
Active area temperature ^{1,5,6}	600 ± 30	500 ± 30	°C
Window	open	Si ARC	
Housing	TO39	SMD	
Estimated lifetime ^{7,8}	> 5 000 h at 740 °C	> 5 000 h at 640 °C	
	> 100 000 h at 600 °C	> 100 000 h at 500 °C	
Absolute max. ratings			
Input power ^{3,5}	1 000	1 000	mW
Housing temperature ⁸	200	200	°C
Active area temperature	740	640	°C

¹ At nominal power

² 25 °C - 700 °C

³ At power on-state

⁴ With hot resistant: 19 Ω for TO39 or 17 Ω for SMD

⁵ At T_{amb} = 25 °C

⁶ Mean of temperature distribution with 10% decrease of hotspot temperature measured by IR camera (0.7-1.1μm)

⁷ Continuous mode, MTTF 63 % (membrane fracture, calculated values based on Arrhenius)

⁸ Including ambient temperature

Typical operating characteristics

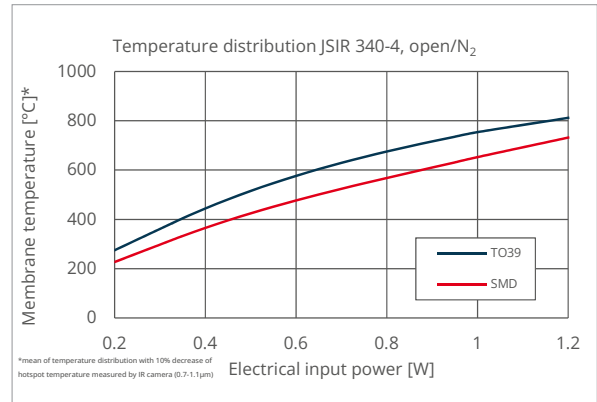
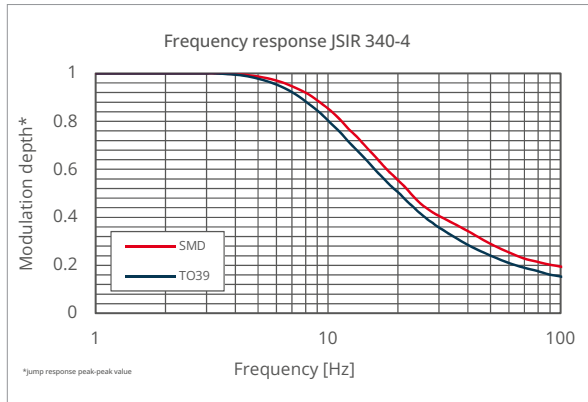
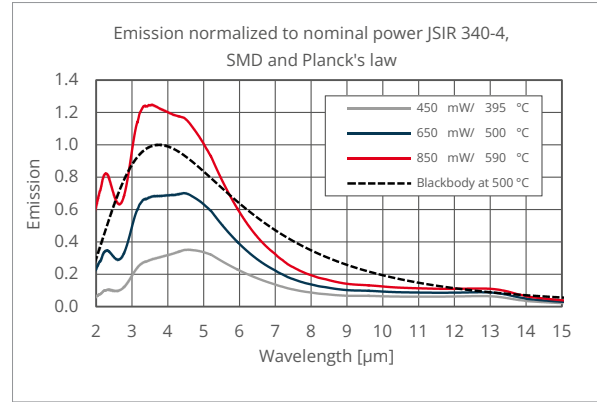
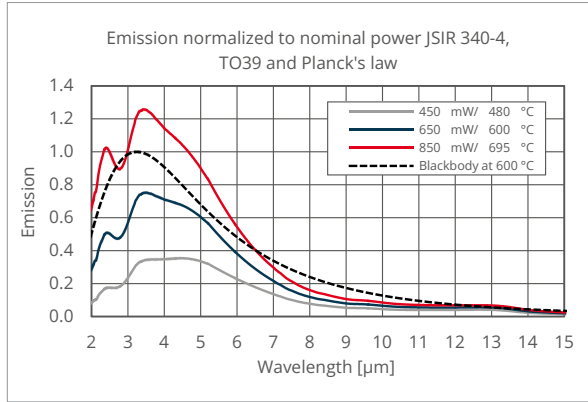

Electrical schemata

Pin out (bottom view)



- Pin 1 – Power 1
- Pin 2 – Case
- Pin 3 – Power 2

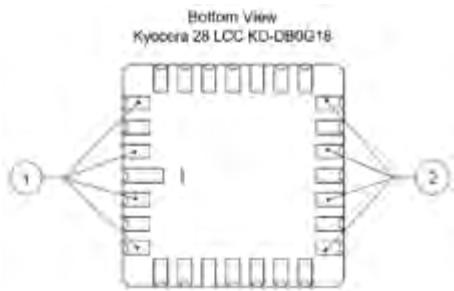

- Pin 1 – Power 1
- Pin 2 – Power 2

Circuits

Equivalent circuit diagram

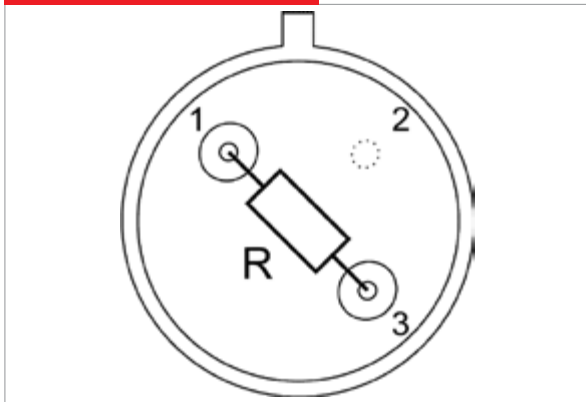

Mechanical drawings

Bottom TO39

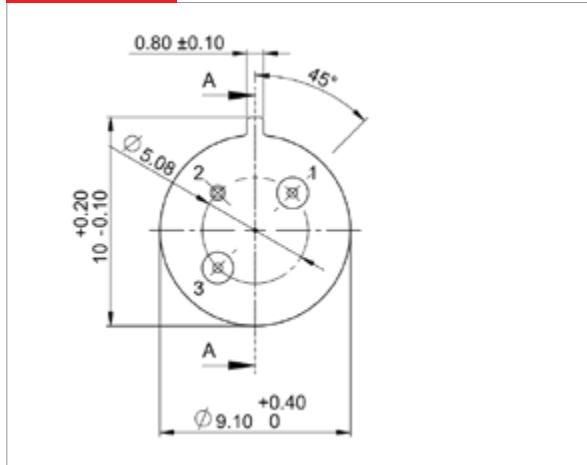

Bottom SMD

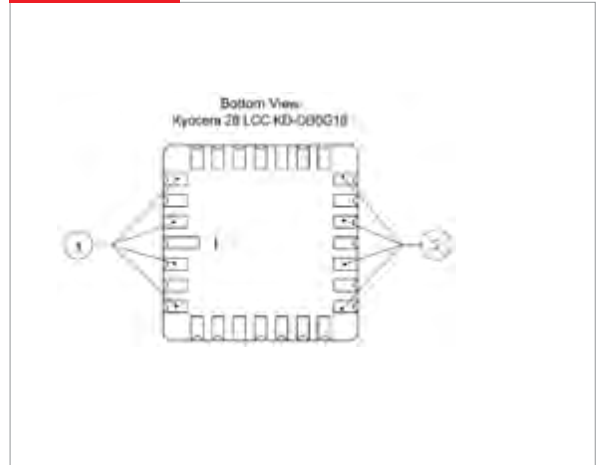

Sectional - TO39 reflector open

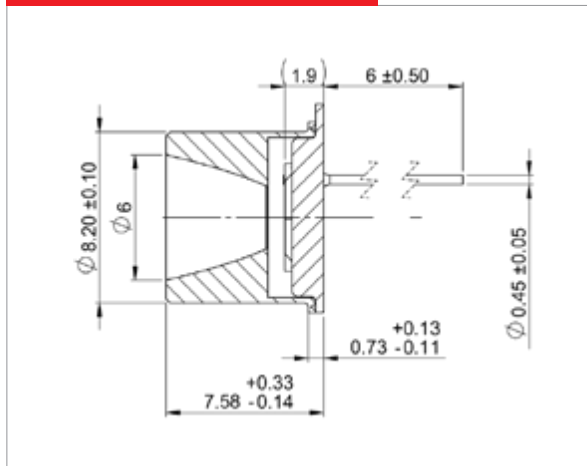

Sectional - SMD with filter

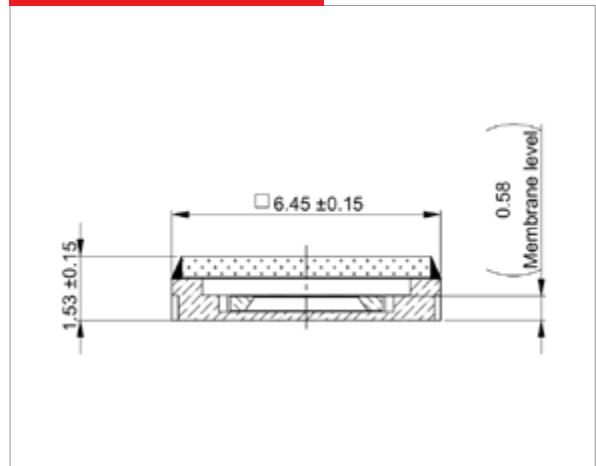

→ All geometrical dimensions in mm

Product overview

Article	Type	Filling gas	Temp. min	Temp. max	Aperture	Window
<u>JSIR340-4-AL-R-D6.0-0-0</u>	TO39 with reflector	None	-20 °C	180 °C	6.0 mm	Open
<u>JSIR340-4-CB-0-S5.0-Air-A7</u>	SMD	None	-20 °C	85 °C	5.0 x 5.0 mm ²	Si ARC

Disclaimer

All rights reserved. All information in this data sheet are based on latest knowledge, results of practical experience and tests carried out. Earlier specifications are hereby invalid. All specifications – technical included – are subject to change without notice. It is the customer's responsibility to ensure that the performance of the product is suitable for customer's specific application. No liability is accepted for indirect damage, in particular for the use or inability to use the product. Any liability we may have is limited to the value of the product itself.